



**YAMAHA**

**2003**

**FZS1000(R)**

**5LV1-AE2**

**SUPPLEMENTARY  
SERVICE MANUAL**



---

## **FOREWORD**

This Supplementary Service Manual has been prepared to introduce new service and data for the FZS1000 (R) 2003. For complete service information procedures it is necessary to use this Supplementary Service Manual together with the following manual.

**FZS1000 (N) 2001 SERVICE MANUAL: 5LV1-AE1**

**FZS1000 (R) 2003  
SUPPLEMENTARY  
SERVICE MANUAL**  
©2002 by Yamaha Motor Co., Ltd.  
First Edition, July 2002  
All rights reserved.  
Any reproduction or unauthorized use  
without the written permission of  
Yamaha Motor Co., Ltd.  
is expressly prohibited.

## NOTICE

This manual was produced by the Yamaha Motor Company, Ltd. primarily for use by Yamaha dealers and their qualified mechanics. It is not possible to include all the knowledge of a mechanic in one manual. Therefore, anyone who uses this book to perform maintenance and repairs on Yamaha vehicles should have a basic understanding of mechanics and the techniques to repair these types of vehicles. Repair and maintenance work attempted by anyone without this knowledge is likely to render the vehicle unsafe and unfit for use.

Yamaha Motor Company, Ltd. is continually striving to improve all its models. Modifications and significant changes in specifications or procedures will be forwarded to all authorized Yamaha dealers and will appear in future editions of this manual where applicable.

**NOTE:** 

---

Designs and specifications are subject to change without notice.

---

## IMPORTANT INFORMATION

Particularly important information is distinguished in this manual by the following.



The Safety Alert Symbol means ATTENTION! BECOME ALERT! YOUR SAFETY IS INVOLVED!



Failure to follow WARNING instructions could result in severe injury or death to the motorcycle operator, a bystander or a person checking or repairing the motorcycle.

**CAUTION:**

A CAUTION indicates special precautions that must be taken to avoid damage to the motorcycle.

**NOTE:**

A NOTE provides key information to make procedures easier or clearer.

## HOW TO USE THIS MANUAL

This manual is intended as a handy, easy-to-read reference book for the mechanic. Comprehensive explanations of all installation, removal, disassembly, assembly, repair and check procedures are laid out with the individual steps in sequential order.

- ① The manual is divided into chapters. An abbreviation and symbol in the upper right corner of each page indicate the current chapter. Refer to “SYMBOLS” on the following page.
- ② Each chapter is divided into sections. The current section title is shown at the top of each page, except in Chapter 3 (“Periodic Checks and Adjustments”), where the sub-section title(-s) appears.
- (In Chapter 3, “Periodic Checks and Adjustments”, the sub-section title appears at the top of each page, instead of the section title.)
- ③ Sub-section titles appear in smaller print than the section title.
- ④ To help identify parts and clarify procedure steps, there are exploded diagrams at the start of each removal and disassembly section.
- ⑤ Numbers are given in the order of the jobs in the exploded diagram. A circled number indicates a disassembly step.
- ⑥ Symbols indicate parts to be lubricated or replaced (see “SYMBOLS”).
- ⑦ A job instruction chart accompanies the exploded diagram, providing the order of jobs, names of parts, notes in jobs, etc.
- ⑧ Jobs requiring more information (such as special tools and technical data) are described sequentially.

⑥

CLUTCH

ENG

②

①

④

⑤

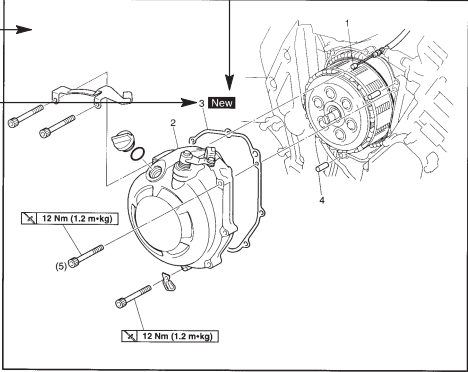

③

⑧

REMOVING THE CLUTCH

1. Straighten the lock washer tab.
2. Loosen:
  - clutch boss nut ①

**NOTE:**

While holding the clutch boss ② with the universal clutch holder ③, loosen the clutch boss nut.

Universal clutch holder  
90890-04086

3. Remove:























- clutch boss nut ①
- lock washer ②
- clutch boss ③

⑦

Order	Job/Part	Q'ty	Remarks
	<b>Removing the clutch cover</b>		
	Engine oil		Remove the parts in the order listed. Drain. Refer to “CHANGING THE ENGINE OIL” in chapter 3.
1	Clutch cable	1	
2	Clutch cover	1	
3	Clutch cover gasket	1	
4	Dowel pin	2	
			For installation, reverse the removal procedure.

5-36

5-40

① GEN INFO 	② SPEC 	
③ CHK ADJ 	④ CHAS 	
⑤ ENG 	⑥ COOL 	
⑦ CARB 	⑧ ELEC 	
⑨ TRBL SHTG ?	⑩ 	
⑪ 	⑫ 	
⑬ 	⑭ 	
⑮ 	⑯ 	⑰ 
⑱ 	⑲ 	⑳ 
㉑ 	㉒ 	㉓ 
㉔ 	㉕ <b>New</b>	

EAS00008

## SYMBOLS

The following symbols are not relevant to every vehicle.

Symbols ① to ⑨ indicate the subject of each chapter.

- ① General information
- ② Specifications
- ③ Periodic checks and adjustments
- ④ Chassis
- ⑤ Engine
- ⑥ Cooling system
- ⑦ Carburetor(-s)
- ⑧ Electrical system
- ⑨ Troubleshooting

Symbols ⑩ to ⑰ indicate the following.

- ⑩ Serviceable with engine mounted
- ⑪ Filling fluid
- ⑫ Lubricant
- ⑬ Special tool
- ⑭ Tightening torque
- ⑮ Wear limit, clearance
- ⑯ Engine speed
- ⑰ Electrical data

Symbols ⑱ to ㉓ in the exploded diagrams indicate the types of lubricants and lubrication points.

- ⑱ Engine oil
- ⑲ Gear oil
- ⑳ Molybdenum disulfide oil
- ㉑ Wheel bearing grease
- ㉒ Lithium soap base grease
- ㉓ Molybdenum disulfide grease

Symbols ㉔ to ㉕ in the exploded diagrams indicate the following:

- ㉔ Apply locking agent (LOCTITE®)
- ㉕ Replace the part

---

## CONTENTS

### SPECIFICATIONS

GENERAL SPECIFICATIONS .....	1
ENGINE SPECIFICATIONS .....	1
CHASSIS SPECIFICATIONS .....	2
CABLE ROUTING .....	3

### PERIODIC CHECKS AND ADJUSTMENTS

ENGINE .....	14
ADJUSTING THE CLUTCH CABLE FREE PLAY .....	14

### OVERHAULING THE ENGINE

CRANKCASE .....	15
CRANKCASE .....	15

### CARBURETORS

CARBURETORS .....	17
CHECKING AND ADJUSTING THE THROTTLE POSITION SENSOR .....	17

### ELECTRICAL

CHECKING THE SWITCHES .....	20
LIGHTING SYSTEM .....	21
CIRCUIT DIAGRAM .....	21
TROUBLESHOOTING .....	22
CHECKING THE LIGHTING SYSTEM .....	24

### TROUBLESHOOTING

FAULTY LIGHTING OR SIGNALING SYSTEM .....	26
HEADLIGHT DOES NOT LIGHT .....	26
HEADLIGHT BULB BURNT OUT .....	26
TAIL/BRAKE LIGHT DOES NOT LIGHT .....	26
TAIL/BRAKE LIGHT BULB BURNT OUT .....	26
TURN SIGNAL DOES NOT LIGHT .....	26
TURN SIGNAL BLINKS SLOWLY .....	26
TURN SIGNAL REMAINS LIT .....	26
TURN SIGNAL BLINKS QUICKLY .....	26
HORN DOES NOT SOUND .....	26

**FZS1000 2003 WIRING DIAGRAM (EUR)**

**FZS1000R 2003 WIRING DIAGRAM (OCE)**







## SPECIFICATIONS

### GENERAL SPECIFICATIONS

Item	Standard	Limit
<b>Model code</b>	5LVF (A) (B) (D) (DK) (E) (GB) (GR) (I) (N) (NL) (S) (SF) (CH) (P) 5LVG (D) 5LVH (F) 5LVJ (AUS)	... ... ... ...

### ENGINE SPECIFICATIONS

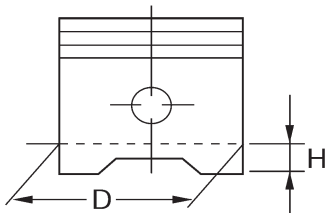
Item	Standard	Limit
<b>Piston</b> Piston-to-cylinder clearance Diameter D 	0.010 ~ 0.035 mm 73.955 ~ 73.970 mm	0.12 mm ...
Height H	5 mm	...
<b>Carburetors</b> ID mark	5LV1 00 (A) (B) (D) (DK) (E) (GB) (GR) (I) (N) (NL) (S) (SF) (CH) (P) (AUS) 5LV3 20 (D) 5LV2 10 (F)	... ... ...



## CHASSIS SPECIFICATIONS

Item	Standard	Limit
<b>Front suspension</b>		
Spring		
Free length	344.0 mm	•••
Spacer length	78.5 mm	•••
Installed length	320.0 mm	•••
Spring rate (K1)	7.8 N/mm (0.8 kg/mm)	•••
Spring rate (K2)	11.8 N/mm (1.2 kg/mm)	•••
Spring stroke (K1)	0 ~ 64 mm	•••
Spring stroke (K2)	64 ~ 140 mm	•••
Optional spring available	No	•••
Fork oil		
Recommended oil	Suspension oil "01" or equivalent	•••
Quantity (each front fork leg)	435 cm <sup>3</sup>	•••
Level (from the top of the inner tube, with the inner tube fully compressed, and without the fork spring)	140 mm	•••



## CABLE ROUTING

- ① Brake hose
  - ② Front fork
- A Fasten the right handlebar switch lead to the handlebar with a plastic band. Point the end of clamp to the downward.
  - B Route the right handlebar switch lead by the right side of the wire guide behind the throttle cable.
  - C Fasten the left handlebar switch lead to the handlebar with a plastic band. Point the end of clamp to the downward.
  - D Fasten the left handlebar switch lead, main switch lead, clutch cable and starter cable with a plastic band. Clamp beneath the horn lead branching position. Do not fasten the horn lead. Direct the end of clamp to the rear inner side of vehicle. Clamp it at 90 mm below the bottom end of the upper bracket.
  - E Route the main switch lead front and left side the another leads.
  - F Pass the horn leads from the outside of vehicle to the inner side and clamp it to the under-bracket. Point the tip of clamp to the front of vehicle. There should be no slack with the lead between horn and clamp. Clamp it at the position of 20 mm from the inner side of the inner tube.
  - G Clamp the brake hose to the inner tube. Cut the surplus part of clamp tip leaving 2 to 10 mm and point the tip of clamp to the front of vehicle. Clamp it at 80 mm from the top end of the under bracket.
  - H Route the brake hose through the brake hose guide.
  - I Route the throttle cable 1 and 2 behind the brake hose and pass it by the left side of wire guide.
  - J Position the remained part of clamp tip within this range.
  - K Direct the horn lead coupler to the rear.

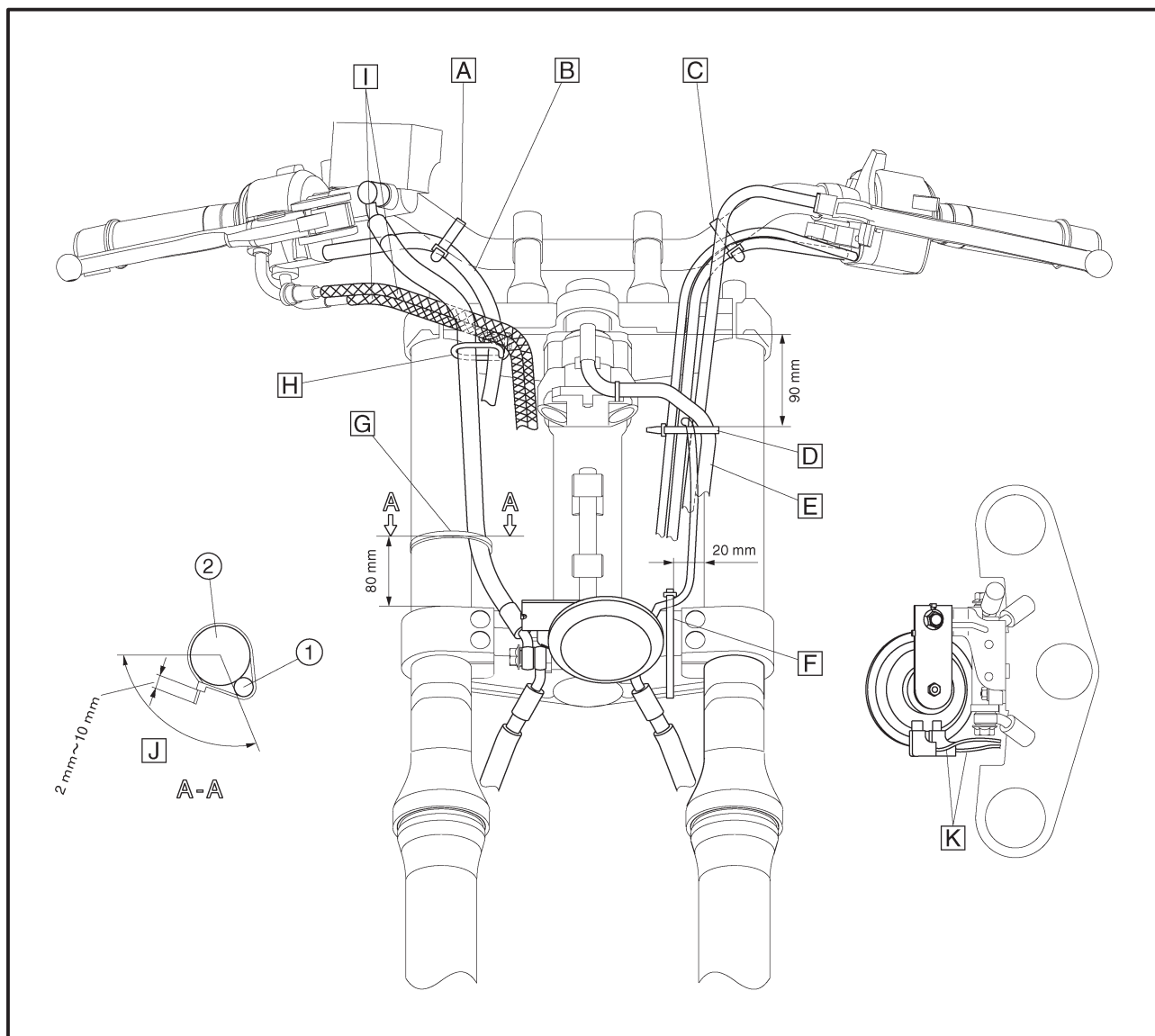

## CABLE ROUTING

SPEC



- ① Fuel pump lead
- ② Fuel pump
- ③ EXUP cable
- ④ Carburetor heater hose
- ⑤ Right handlebar switch lead
- ⑥ Throttle cable 2
- ⑦ Throttle cable 1
- ⑧ Radiator fan motor lead
- ⑨ Coolant reservoir tank over flow hose
- ⑩ Fuel tank drain hose
- ⑪ Fuel tank breather hose
- ⑫ White paint mark
- ⑬ Rear brake light switch lead
- ⑭ Neutral switch lead
- ⑮ Speed sensor lead
- ⑯ Pickup coil lead

- ⑰ Handlebar upper bracket
- ⑱ Brake hose guide
- ⑲ Front brake hose

- A** Fasten the fuel pump lead, pickup coil lead, neutral switch lead, speed sensor lead, rear brake light switch lead and fuel pump with a plastic clamp. Pass the clamp tip between the frame and rear fender and point it to the downward.
- B** Fasten the fuel hose, pickup coil lead, neutral switch lead and speed sensor lead with a plastic clamp under the fuel hose. Place the fitting part on the upward.
- C** Put the EXUP cable into the air box cover.
- D** Clamp the throttle position sensor lead to the carburetor with a steel clamp.

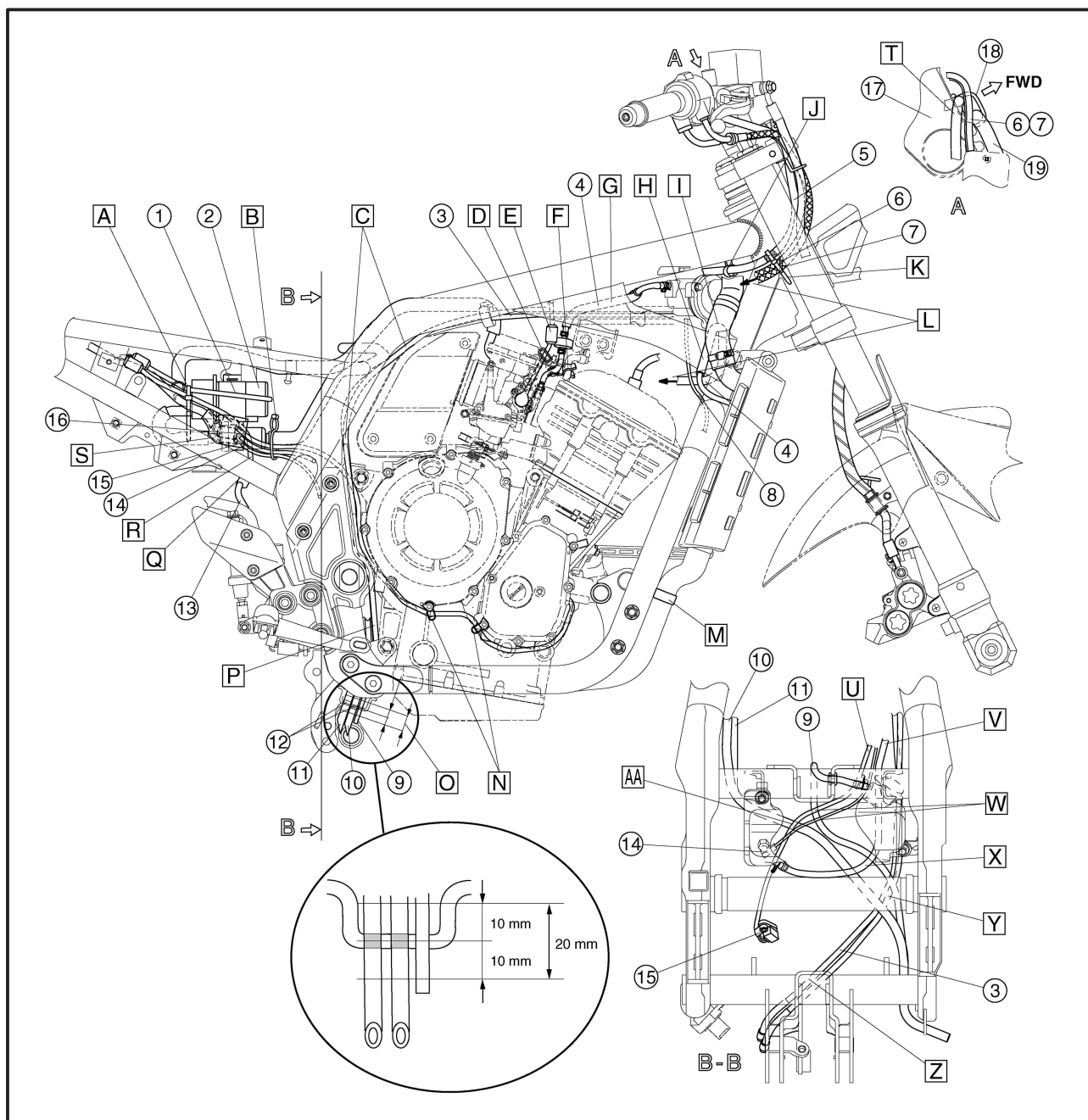

## CABLE ROUTING

SPEC



- E** Route the throttle position sensor lead inward the EXUP cable.
- F** Clamp the AI system hose and carburetor heater hose with a plastic clamp.
- G** Route the carburetor heater hose inside the EXUP cable.
- H** Route the carburetor heater hose between frame and radiator fan motor lead.
- I** Route the carburetor heater hose over the frame.
- J** Clamp the right handlebar switch lead to the frame with a plastic clamp.
- K** Align the taping section of the right handlebar switch lead with the weld beads of tank rail and clamp with the throttle cables 1 and 2. Point the tip of clamp to the downward outside of the vehicle.
- L** To the carburetor.
- M** Fasten the radiator hose with a plastic band.
- N** Fasten the pickup coil lead with a steel clamp.
- O** Route the coolant reservoir tank over flow hose, fuel tank drain hose and fuel tank breather hose through the frame hose holder from the inside of the vehicle to the outside. At this time, pull the fuel tank drain hose and fuel tank breather hose so that the white paint marks are within a 20 mm range.
- P** Route the EXUP cable forward the another hoses, and upward the engine mounting bracket.
- Q** Fasten the rear brake light switch lead with a plastic guide.
- R** Route the rear brake light switch lead inside the another leads.
- S** Insert the all couplers into the rubber cover.

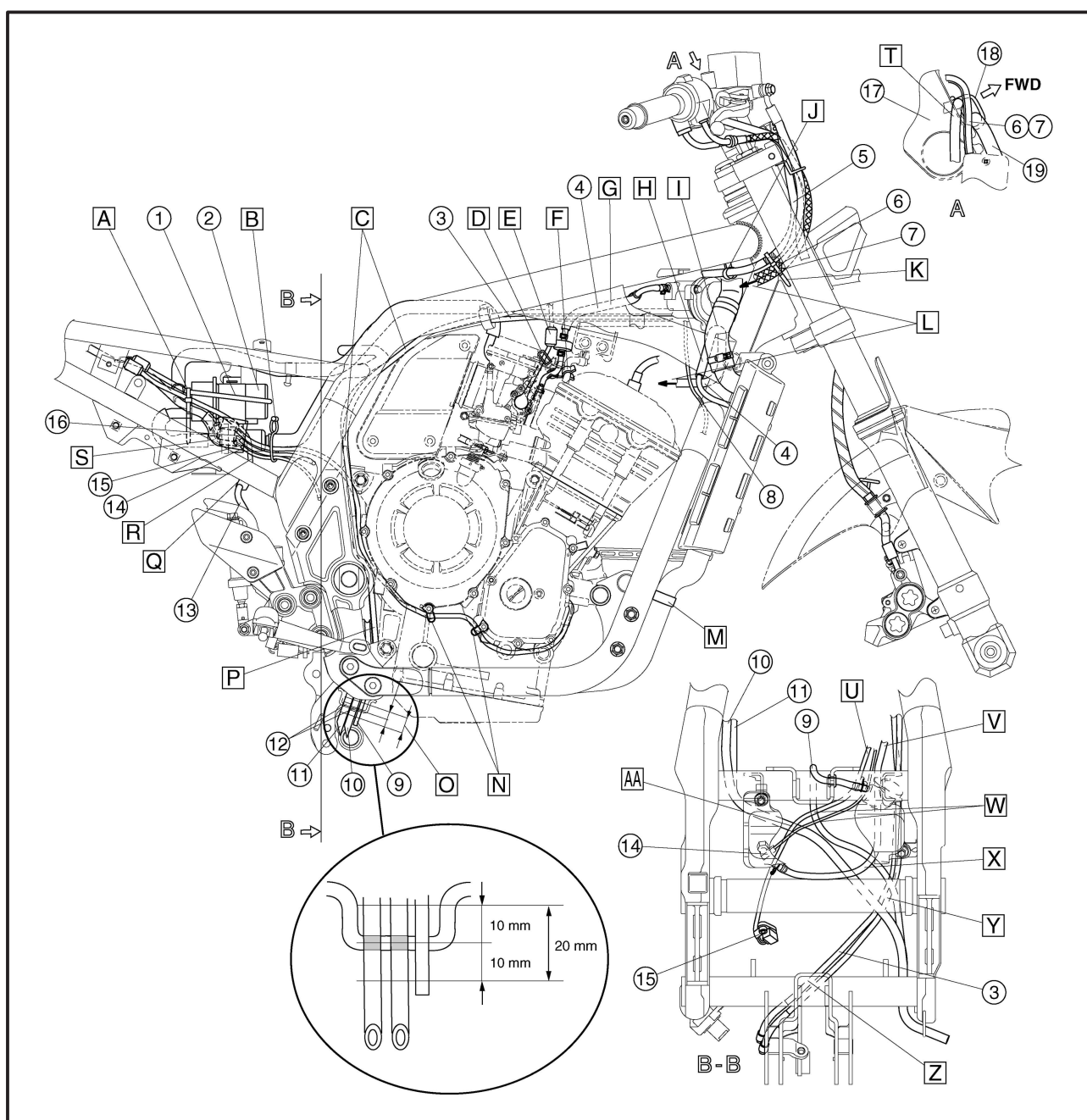



- T** Route the right handlebar switch lead between handle upper bracket and wire guide.
- U** Route the neutral switch lead and speed sensor lead left side the coolant reservoir hose.
- V** Route the coolant reservoir hose left side the engine mounting bracket.
- W** Route the coolant reservoir over flow hose forward the neutral switch lead and speed sensor lead.
- X** Route the coolant reservoir hose backward the another hoses.
- Y** Route the EXUP cable forward the another hoses.
- Z** Route the EXUP cable forward the frame cross pipe.
- AA** Route the fuel tank drain hose and fuel tank breather hose forward the neutral switch lead and speed sensor lead.

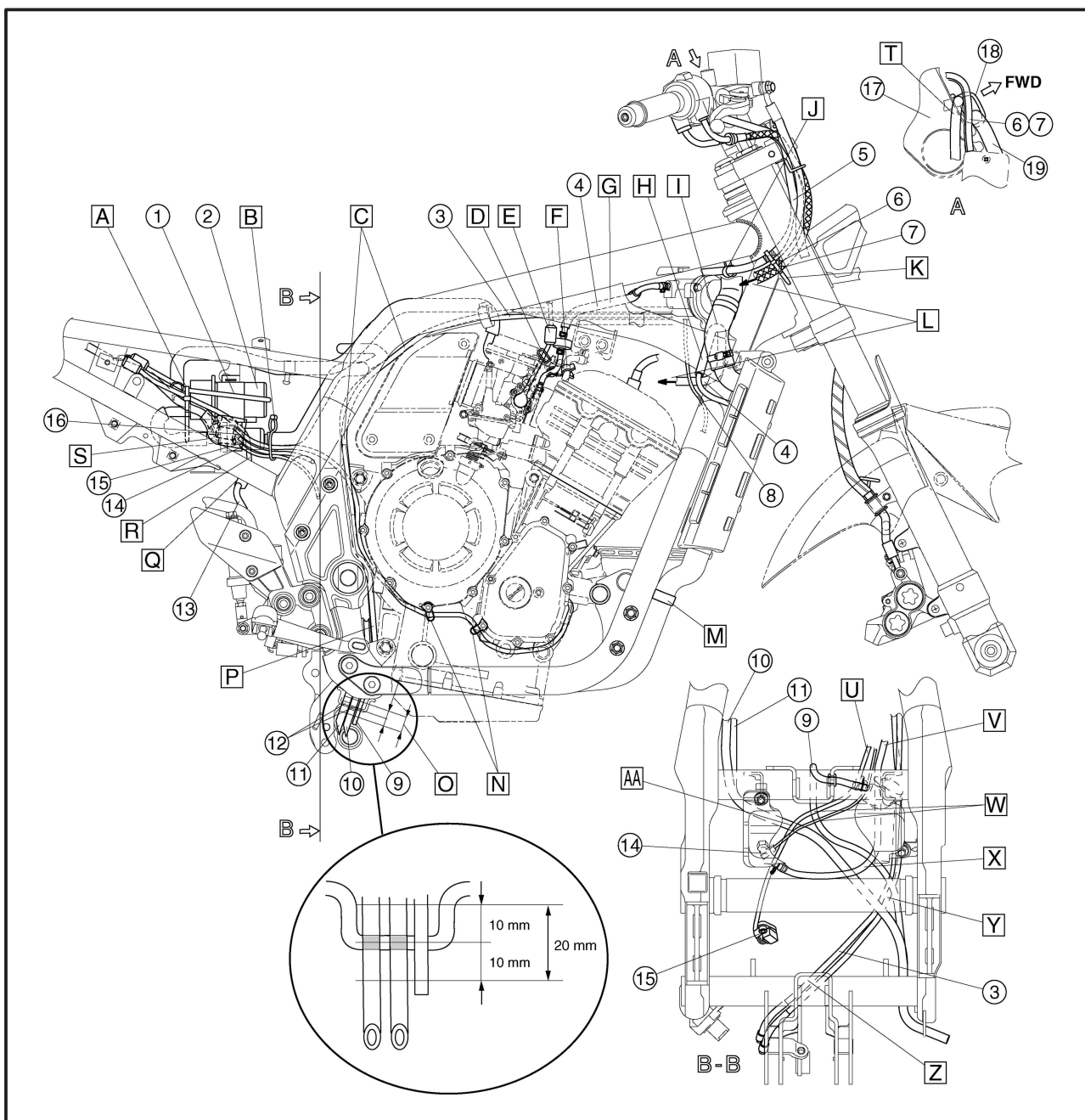

## CABLE ROUTING

SPEC



- ① Starter cable
- ② Clutch cable
- ③ Left handlebar switch lead
- ④ Min switch lead
- ⑤ EXUP motor
- ⑥ Starting circuit cut-off relay
- ⑦ Starter motor lead
- ⑧ Radiator fan motor relay
- ⑨ Sidestand switch lead
- ⑩ Air filter case drain hose
- ⑪ Oil level switch lead
- ⑫ A.C. magneto lead
- ⑬ Coolant pipe
- ⑭ Carburetor heater hose
- ⑮ Throttle cable 1
- ⑯ Throttle cable 2

- ⑰ Spark plug leads
- ⑱ EXUP cable

- A** Fasten the main switch lead and left handlebar switch lead to the frame with a plastic band.
- B** Fasten the coolant hose and carburetor heater hose with a plastic band.  
Clamp it at 50 mm from the top end of the cylinder head cover.
- C** Route the spark plug lead #1 outside of the starter cable and carburetor heater hose, and under the clutch cable and rectifier/regulator lead.
- D** Fasten the clutch cable with a plastic clamp to the frame.
- E** Fasten the wire harness with a plastic clamp to the frame.

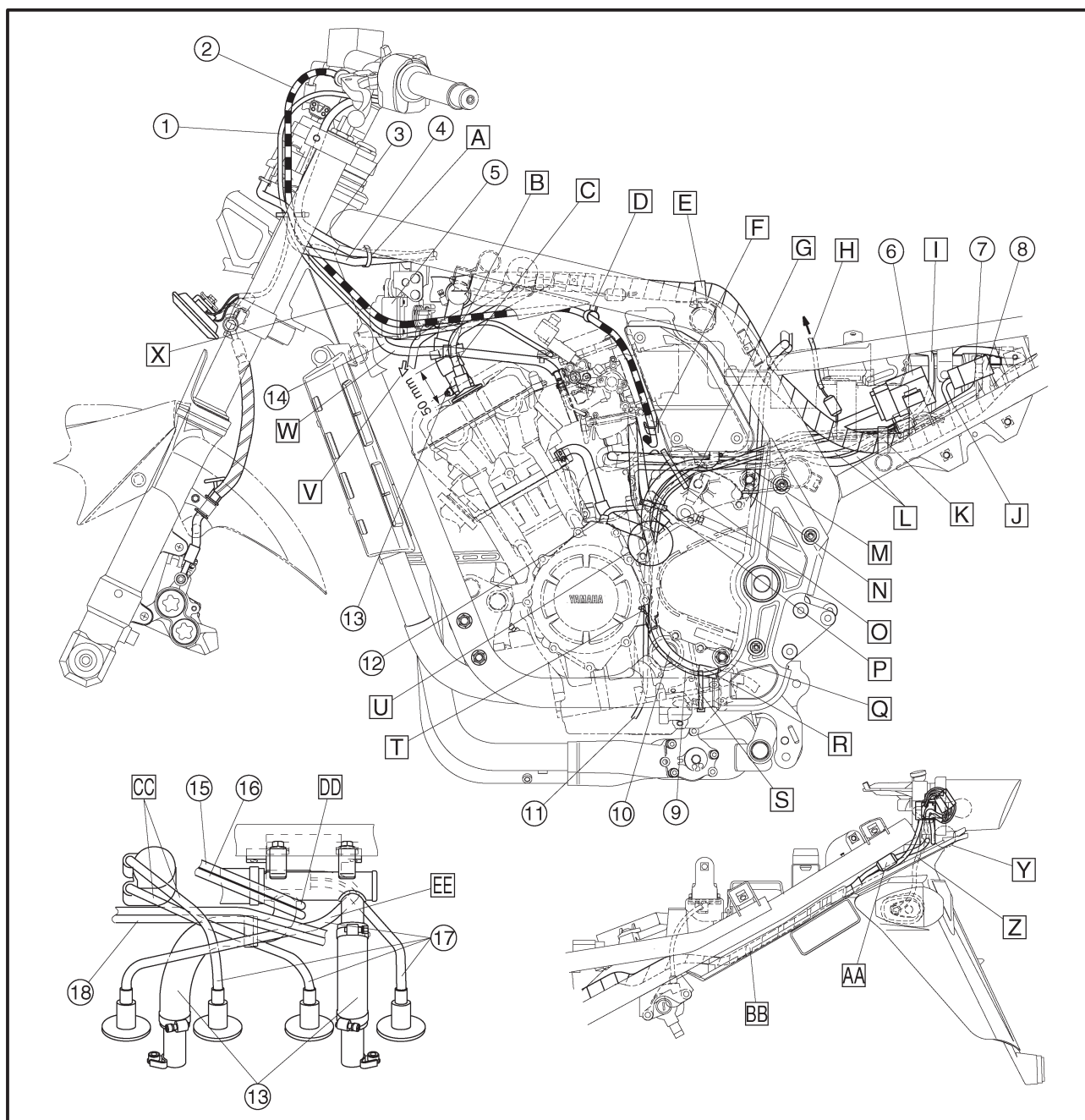

## CABLE ROUTING

SPEC



- F** Fasten the clutch cable with a steel clamp.
- G** Route the all leads on the shift shaft.
- H** Route the fuel sender lead inside of the seat rail.
- I** Route the battery negative lead forward of the frame stay.
- J** Route the wire harness around inside of the rear fender rib.
- K** Fasten the wire harness, sidestand switch lead and oil level switch lead to the frame with a plastic clamp. Do not fasten the A.C. magneto lead coupler (white).
- L** Route the starter motor lead and battery negative lead inside of the clamp.
- M** Route the all leads outside of fuel hose.
- N** Route the fuel hose the clamp of the frame.
- O** Fasten the sidestand switch lead, oil level switch lead, A.C. magneto lead, starter motor lead, battery negative lead and air filter case drain hose with a plastic clamp.
- P** Fasten the sidestand switch lead, oil level switch lead, A.C. magneto lead and air filter case drain hose with a plastic clamp.
- Q** Clamp the sidestand switch lead to the frame.
- R** Route the air filter case drain hose through inside the sidestand switch lead, and put end of the hose backward.
- S** Fasten the sidestand switch lead to the frame with a clamp.
- T** Fasten the sidestand switch lead and oil level switch lead with a plastic clamp. Do not crush the air filter case drain hose.

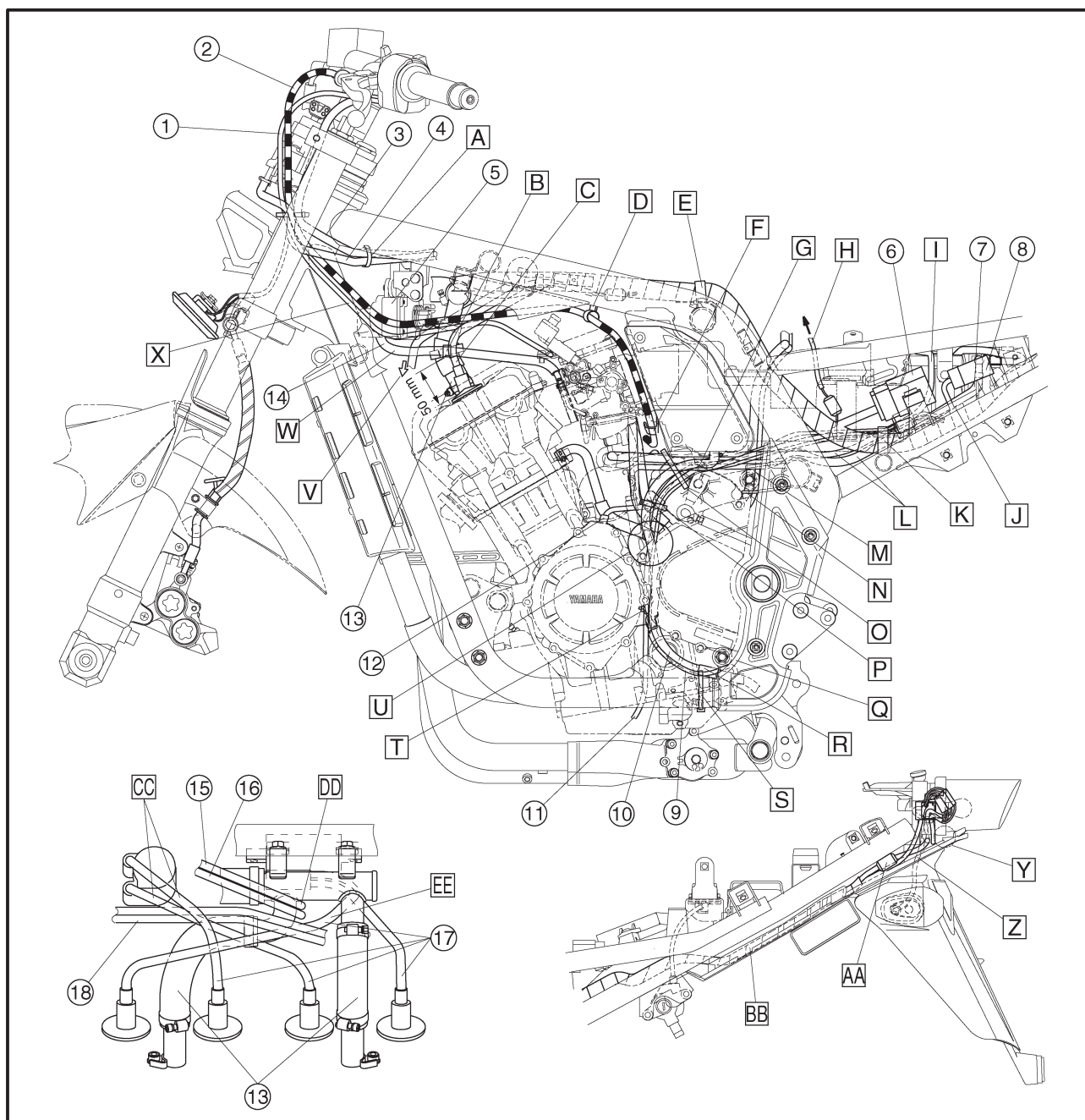



## CABLE ROUTING

SPEC



- U** Route the sidestand switch lead oil level switch lead outside the hose.
- V** To the cylinder #4.
- W** Route the carburetor heater hose through outside of the coolant pipe.
- X** Route the starter cable through outside of the coolant hose and upward of the carburetor heater hose.
- Y** Tail/brake light and right turn signal light lead should not be stick out from the gap between the rear fender and tail/brake light.
- Z** Route the turn signal light lead through hole on the rear fender.
- AA** Push in the coupler of tail/brake light leads between the rear fender and frame.
- BB** Push in the wire harness between ribs.
- CC** Route the spark plug leads #2, 3 between EXUP cable and spark plug lead #4.
- DD** Route the throttle cables 1 and 2 between right coolant hose and left coolant hose, and upward of the EXUP cable.
- EE** Route the spark plug lead #4 forward of the coolant hose and downward of the EXUP cable.

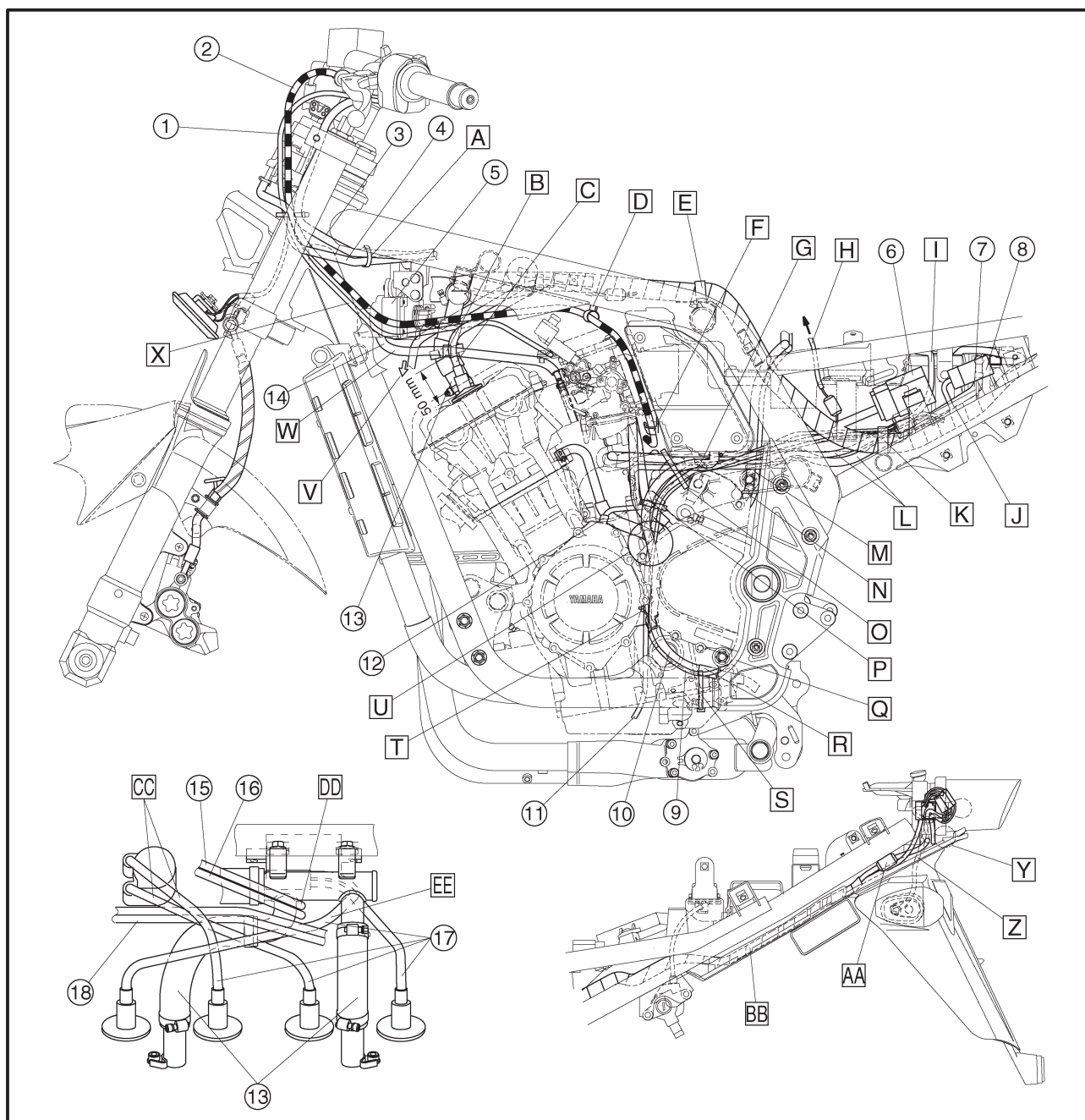

## CABLE ROUTING

SPEC



- |                              |                               |                                |                                   |
|------------------------------|-------------------------------|--------------------------------|-----------------------------------|
| ① Clutch cable               | ⑩ Right handlebar switch lead | ⑲ Battery                      | ③① Battery negative lead          |
| ② Left handlebar switch lead | ⑪ Coolant reservoir tank hose | ⑳ Emergency engine stop switch | ③② Starting circuit cut-off relay |
| ③ Main switch lead           | ⑫ Ignition coil               | ㉑ Turn signal relay            | ③③ White mark                     |
| ④ Starter cable              | ⑬ Fuel tank drain hose        | ㉒ Fuse box                     | ③④ Wire harness                   |
| ⑤ EXUP motor lead            | ⑭ Fuel tank breather hose     | ㉓ Igniter unit                 | ③⑤ Ignition coil lead             |
| ⑥ Radiator fan motor lead    | ⑮ Fuel hose                   | ㉔ Rear turn signal light lead  | ③⑥ White mark                     |
| ⑦ Thermo switch lead         |                               | ㉕ Tail/brake light lead        |                                   |
| ⑧ Throttle cable 1           |                               | ㉖ Seat lock cable              |                                   |
| ⑨ Throttle cable 2           |                               | ㉗ Immobilizer coupler (free)   |                                   |
|                              |                               | ㉘ Starter relay                |                                   |
|                              |                               | ㉙ Battery positive lead        |                                   |
|                              |                               | ㉚ Radiator fan motor relay     |                                   |

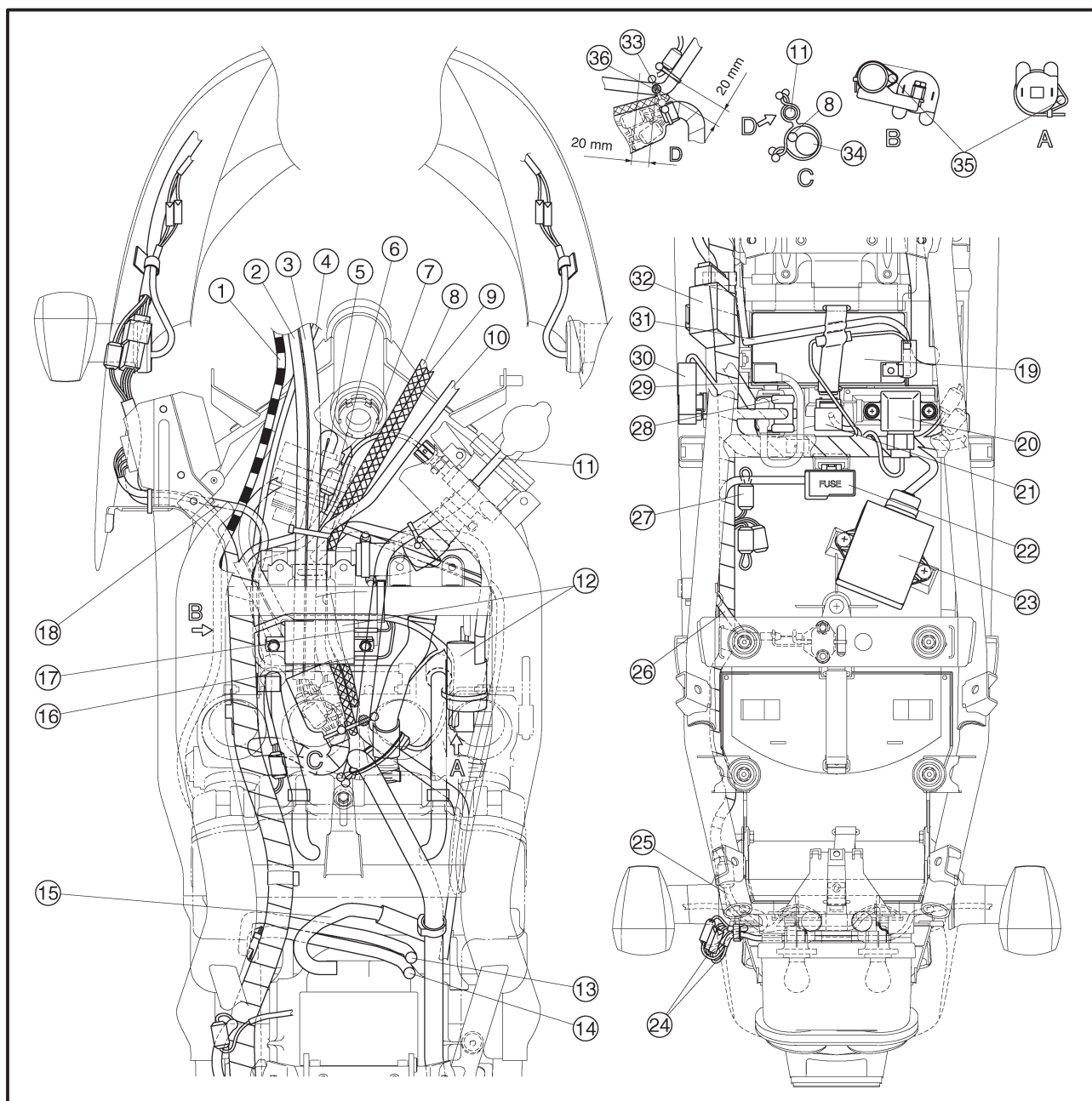

## CABLE ROUTING

SPEC



- A** Route the throttle cables through right side of the radiator fan motor lead and thermo switch lead and EXUP motor lead
- B** Clamp the right turn signal lead (front).
- C** Route the all leads through between frame cross pipe and bracket.
- D** Route the coolant reservoir tank hose through under the cross pipe.
- E** Do not excessively bend the throttle cable.
- F** Fasten the ignition coil and ignition coil lead with a plastic band and end of the plastic band downward.
- G** Route the throttle position sensor lead through under the air vent hose.
- H** It is allowed to select either color for leads. Point the lead toward the inner side.
- I** Clamp the EXUP cable with a plastic clamp and clamp open end upward.
- J** Route the coolant reservoir tank hose through under the air vent hose and AI system hose.
- K** Route the coolant reservoir tank hose through under the frame cross pipe.
- L** Clamp the fuel hose with a plastic clamp.
- M** Put the fuel tank breather hose into the forward nipple on the fuel tank.
- N** Put the fuel tank breather hose into the backward nipple on the fuel tank.
- O** Insert the positioning clamp of wire harness to the T-stud of frame.
- P** Fasten the fuel hose and AI system hose with a plastic band and end of band downward.
- Q** Put air vent hoses (left and right) into air filter case groove.
- R** Route the air vent hose through over the wire harness.

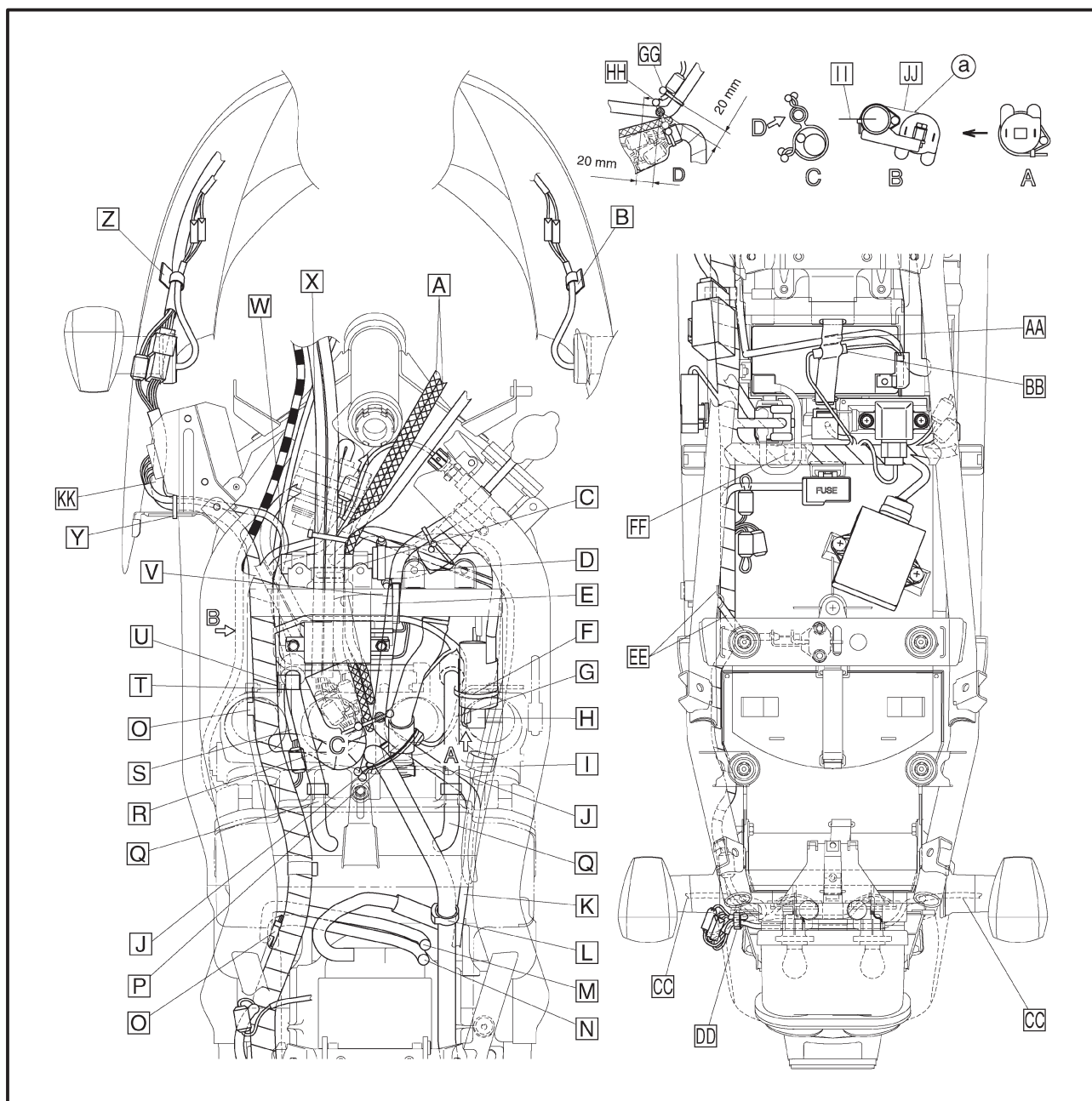

## CABLE ROUTING

SPEC



- S** Route the rectifier/regulator lead through under the wire harness.
  - T** Place the coupler of each lead in the coupler cover.
  - U** Clamp the wire harness and rectifier/regulator lead with a clamp.
  - V** Attach the ignition coil lead and clamp it with the frame cross pipe at the right side of bracket. However, do not clamp a bare lead.
  - W** Route the rectifier/regulator lead through over the radiator fan motor lead and EXUP motor lead.
  - X** Clamp the left and right handlebar switch leads, main switch lead, EXUP motor lead, radiator fan motor lead and thermo switch lead with a plastic clamp.
- There should be no interference of each lead with the throttle cable and spark plug leads.
- Y** Clamp the stay, wire harness and rectifier/regulator leads. Cut the surplus part of clamp. Leave the remained part to be within 3 mm after cutting.
  - Z** Clamp the left turn signal lead and headlight sub-wire harness.
  - AA** Clamp the battery negative lead with a battery band.
  - BB** Insert the coupler of negative lead to the hole of battery band.
  - CC** To the turn signal light.
  - DD** Fasten the tail/brake light lead and turn signal light lead, and put in the groove on the tail/brake light bracket.
  - EE** Put the lock cable into the groove on the rear fender.
  - FF** Fasten the battery positive lead to the frame with a plastic clamp.

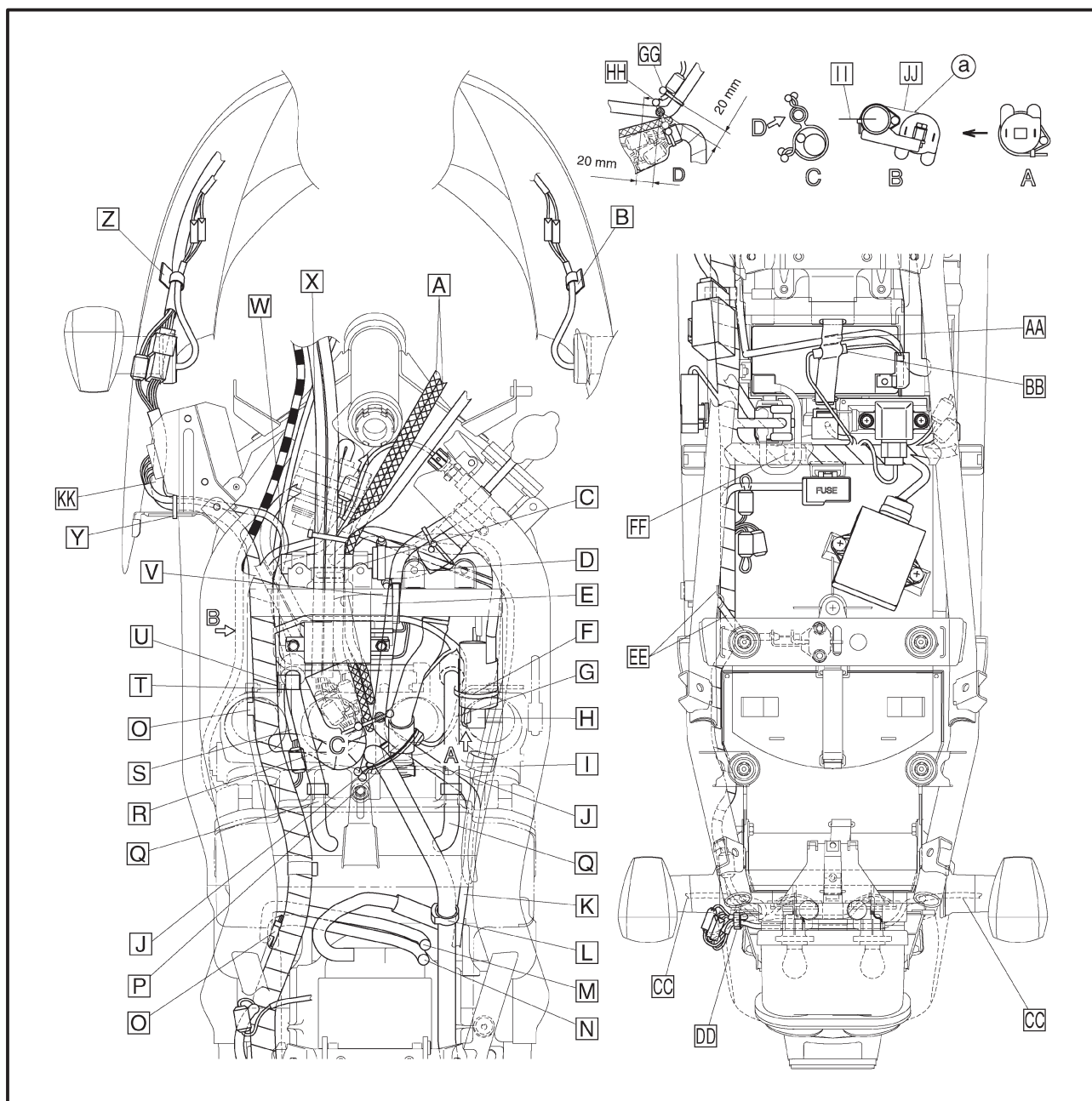



- GG** Clamp the throttle position sensor lead with the coolant reservoir tank hose in front of the coupler. Point the tip of clamp to the downward.
- HH** Place the white mark on the coolant reservoir tank hose within the range of  $\pm 20$  mm to the clamp position along the axial direction of hose.
- II** Position the fitting part of clamp lower than the centerline of frame.
- JJ** Push in the ignition coil lead between the cross pipe and ignition coil under this line (a).
- KK** Route the wire harness beneath the rectifier/regulator.

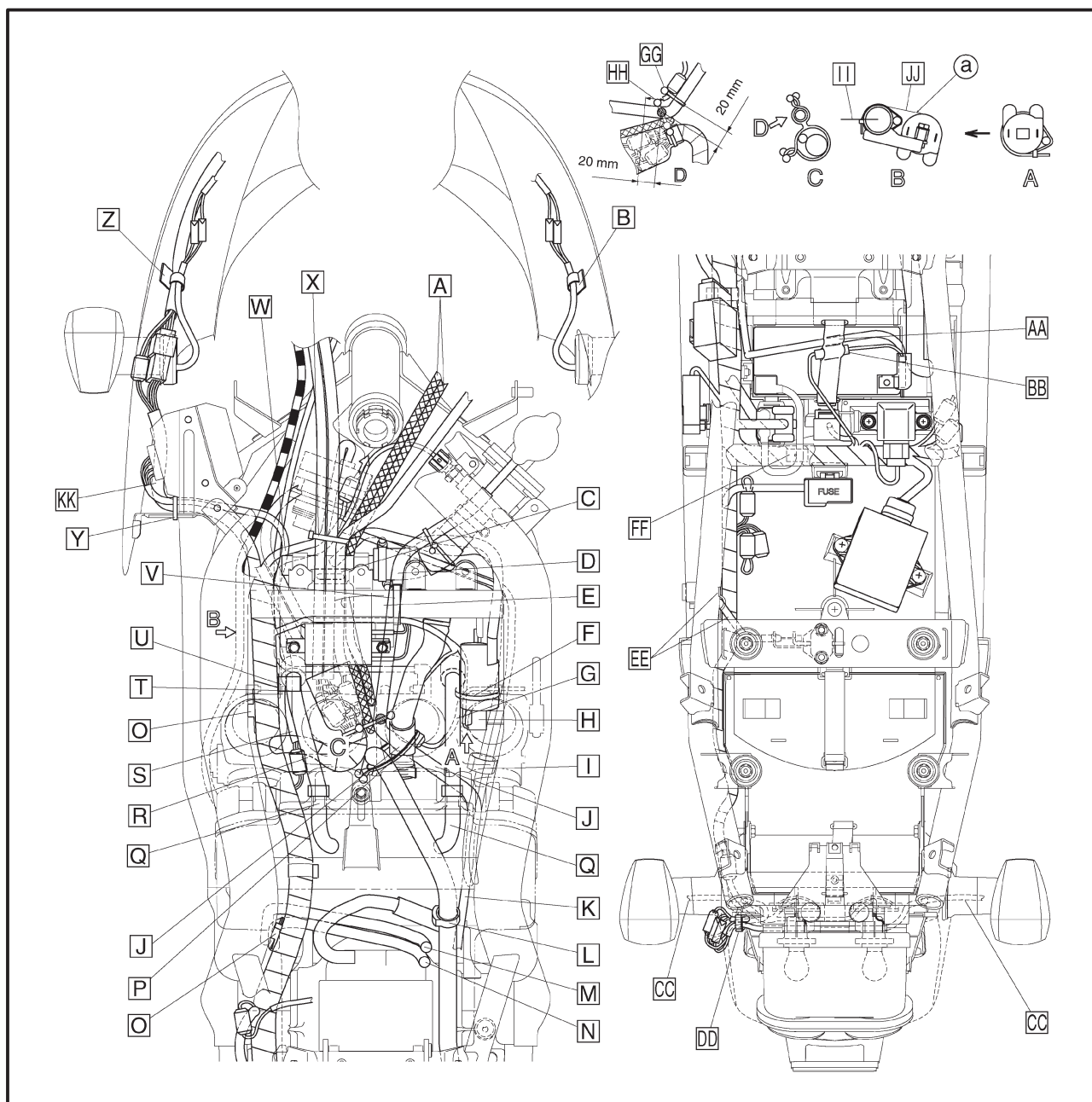





EAS00381

## OVERHAULING THE ENGINE

### CRANKCASE CRANKCASE

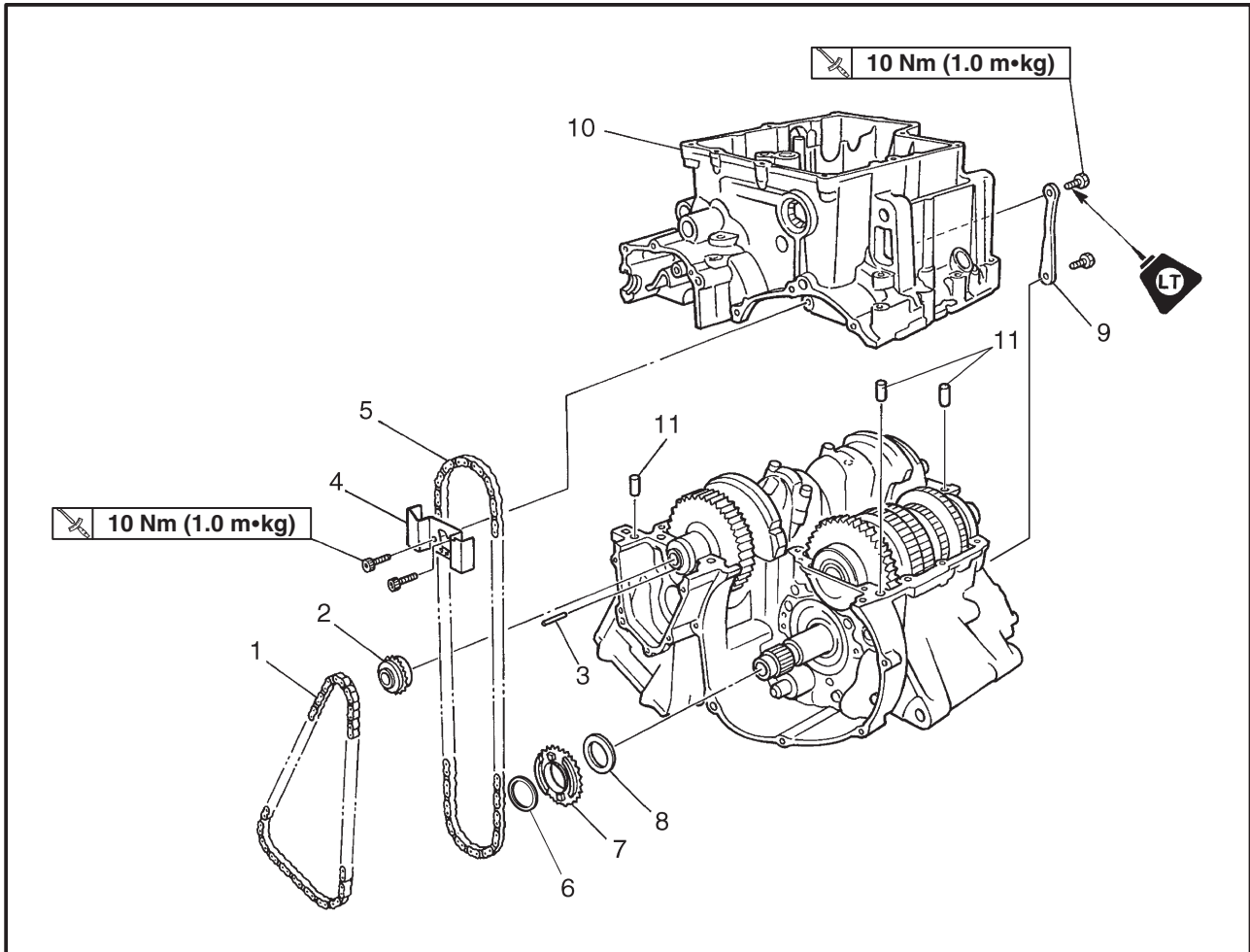

Order	Job/Part	Q'ty	Remarks
	<b>Removing the crankcase</b>		Remove the parts in the order listed.
	Engine		Refer to "ENGINE". (Manual No.: 5LV1-AE1)
	Cylinder head		Refer to "CYLINDER HEAD". (Manual No.: 5LV1-AE1)
	Pickup coil and pickup coil rotor		Refer to "PICKUP COIL". (Manual No.: 5LV1-AE1)
	Stator coil assembly		Refer to "GENERATOR". (Manual No.: 5LV1-AE1)
	Clutch housing and starter clutch idle gear		Refer to "CLUTCH". (Manual No.: 5LV1-AE1)
	Oil/water pump assembly		Refer to "OIL PAN AND OIL PUMP". (Manual No.: 5LV1-AE1)
1	Timing chain	1	
2	Crankshaft sprocket	1	
3	Pin	1	
4	Oil/water pump assembly drive chain guide	1	

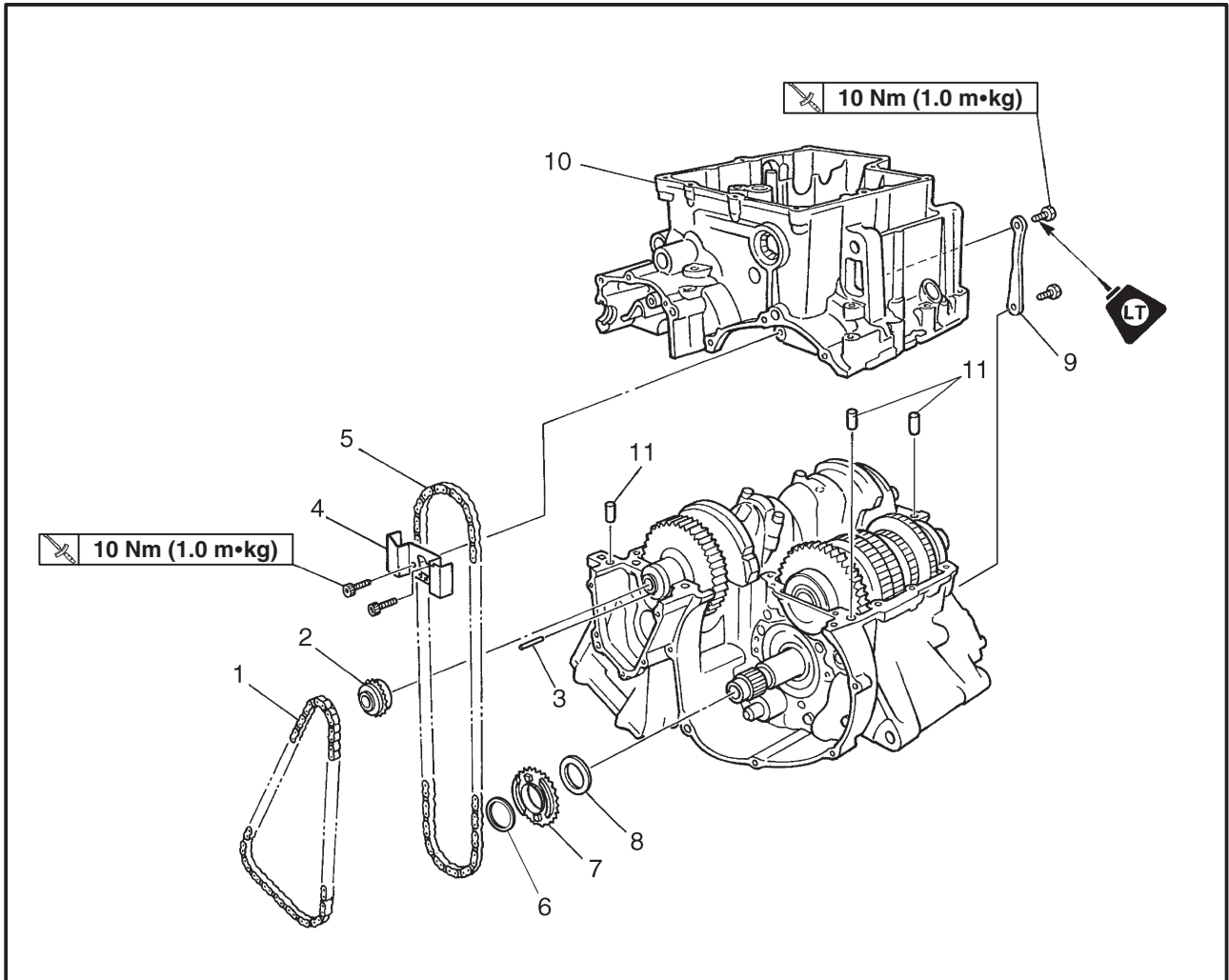

Order	Job/Part	Q'ty	Remarks
5	Oil/water pump assembly drive chain	1	For installation, reverse the removal procedure.
6	Washer	1	
7	Oil/water pump assembly drive sprocket	1	
8	Washer	1	
9	Plate	1	
10	Lower crankcase	1	
11	Dowel pin	3	





EAS00502

## CARBURETORS

### CARBURETORS

#### CHECKING AND ADJUSTING THE THROTTLE POSITION SENSOR

**NOTE:** \_\_\_\_\_

Before adjusting the throttle position sensor, the engine idling speed should be properly adjusted.

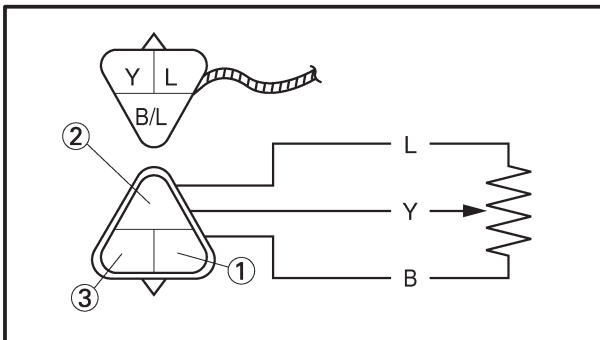

1. Check:
  - throttle position sensor (installed on the throttle body)

- a. Disconnect the throttle position sensor coupler from the throttle position sensor.
- b. Connect the pocket tester ( $\Omega \times 1k$ ) to the throttle position sensor.

**Tester positive probe** → blue terminal ①  
**Tester negative probe** → black terminal ②

- c. Measure the maximum throttle position sensor resistance.  
 Out of specification → Replace the throttle position sensor.



**Maximum throttle position sensor resistance**  
**4.0 ~ 6.0 k $\Omega$  at 20°C**  
**(blue – black)**

- d. Connect the pocket tester ( $\Omega \times 1k$ ) to the throttle position sensor.

**Tester positive probe** → yellow terminal ③  
**Tester negative probe** → black terminal ②

- e. While slowly opening the throttle, check that the throttle position sensor resistance is within the specified range.

**NOTE:** \_\_\_\_\_

Check mainly that the resistance changes gradually when turning the throttle, since the readings (from closed to wide-open throttle) may differ slightly from those specified.

Out of specification or the resistance changes abruptly → Go to step 2 below.



**Throttle position sensor resistance**

0.4 ~ 5.4 kΩ at 20°C  
(yellow – black)

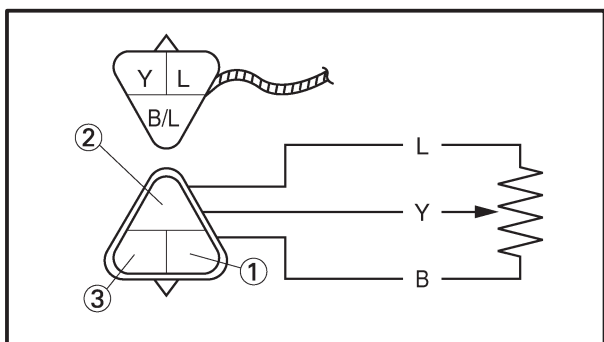

2. Check:

- throttle position sensor angle



- Connect the throttle position sensor coupler to the throttle position sensor.
- Connect the pocket tester (DC 20 V) to the throttle position sensor coupler.

**Tester positive probe** → blue terminal ①

**Tester negative probe** →  
black terminal ②

- Measure the throttle position sensor input voltage.



**Throttle position sensor input voltage**

4.95 ~ 5.05 V

Out of specification

- Check the throttle sensor coupler connection.
- Check the entire throttle sensor system's wiring.



3. Adjust:

- throttle position sensor angle



- Loosen the throttle position sensor screws ④.
- Connect the pocket tester (DC20 V) to the throttle position sensor coupler.

**Tester positive probe** →

yellow terminal ③

**Tester negative probe** →

black terminal ②

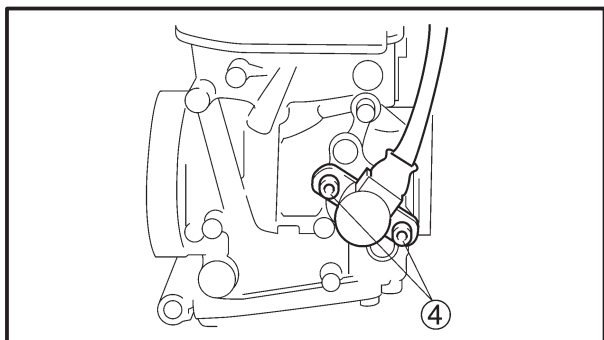

## CARBURETORS

CARB



- c. Adjust the throttle position sensor angle so the measured output voltage is within the specified range.



**Throttle position sensor output voltage**

**0.65 ~ 0.75 V**

- d. After adjusting the throttle position sensor angle, tighten the throttle position sensor screws ④.



**NOTE:** \_\_\_\_\_

To tighten the screws ④ when the adjustment of throttle position sensor is complete, make sure to tighten it while monitoring the measurement value without detaching the tester probe.



EAS00731

## ELECTRICAL

### CHECKING THE SWITCHES

Check each switch for damage or wear, proper connections, and also for continuity between the terminals. Refer to "CHECKING SWITCH CONTINUITY". (Manual No.: 5LV1-AE1)

Damage/wear → Repair or replace the switch.

Improperly connected → Properly connect.

Incorrect continuity reading → Replace the switch.

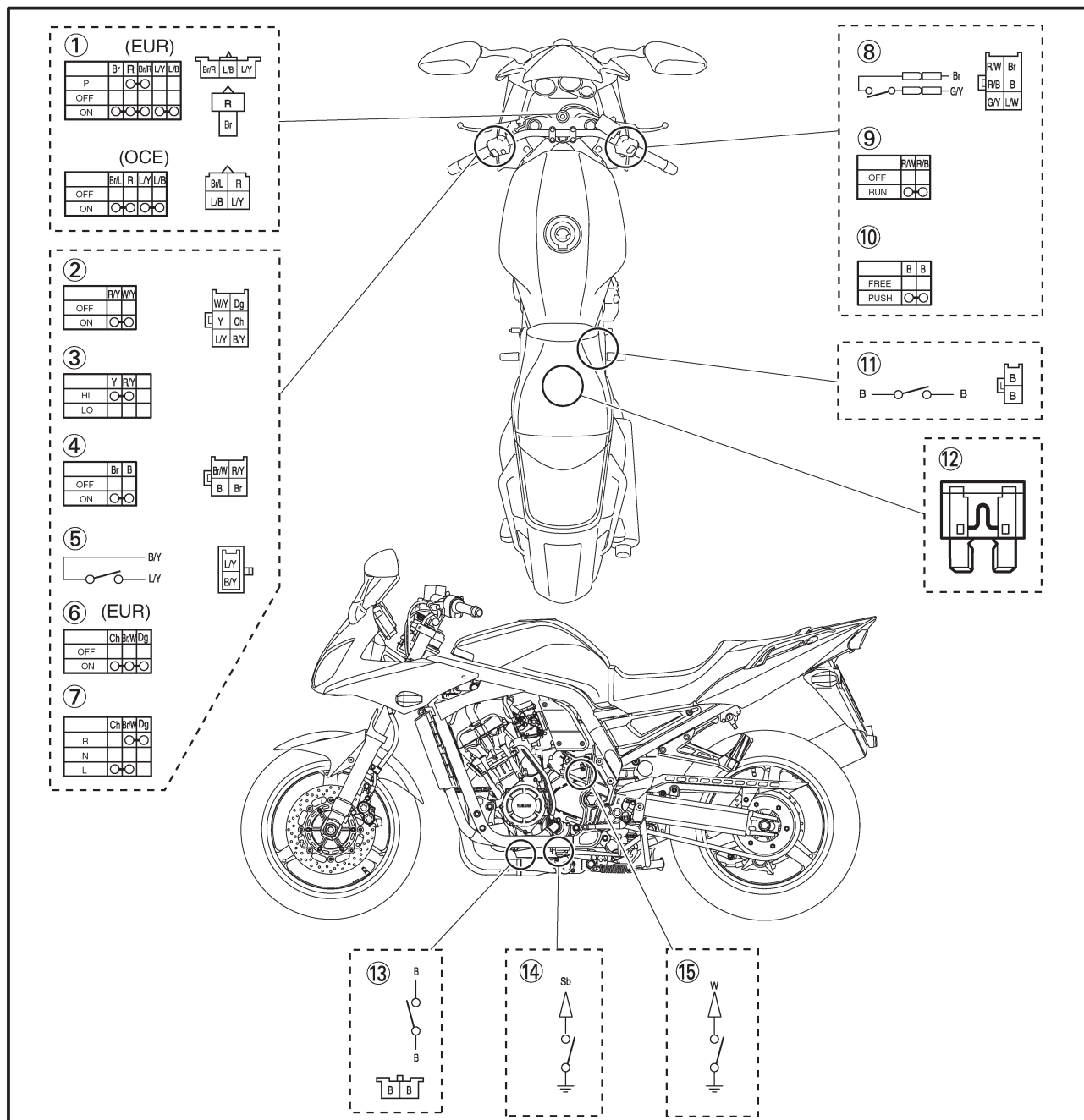

- ① Main switch
- ② Pass switch
- ③ Dimmer switch
- ④ Horn switch
- ⑤ Clutch switch
- ⑥ Hazard switch

- ⑦ Turn signal switch
- ⑧ Front brake light switch
- ⑨ Engine stop switch
- ⑩ Start switch
- ⑪ Rear brake light switch

- ⑫ Fuse
- ⑬ Side stand switch
- ⑭ Neutral switch
- ⑮ Oil level switch

EAS00780

**LIGHTING SYSTEM  
CIRCUIT DIAGRAM**

- |                            |                             |
|----------------------------|-----------------------------|
| ① Main switch              | ④⑤ Dimmer switch            |
| ⑤ Battery                  | ⑤④ Headlight                |
| ⑦ Fuse (main)              | ⑤⑤ Tail/brake light         |
| ⑮ Igniter                  | ⑤⑦ Fuse (ignition)          |
| ③① Hi-beam indicator light | ⑥① Fuse (headlight)         |
| ③④ Meter light             | ⑥⑤ Headlight relay (on/off) |
| ④④ Pass switch             | ⑥⑥ Headlight relay (dimmer) |

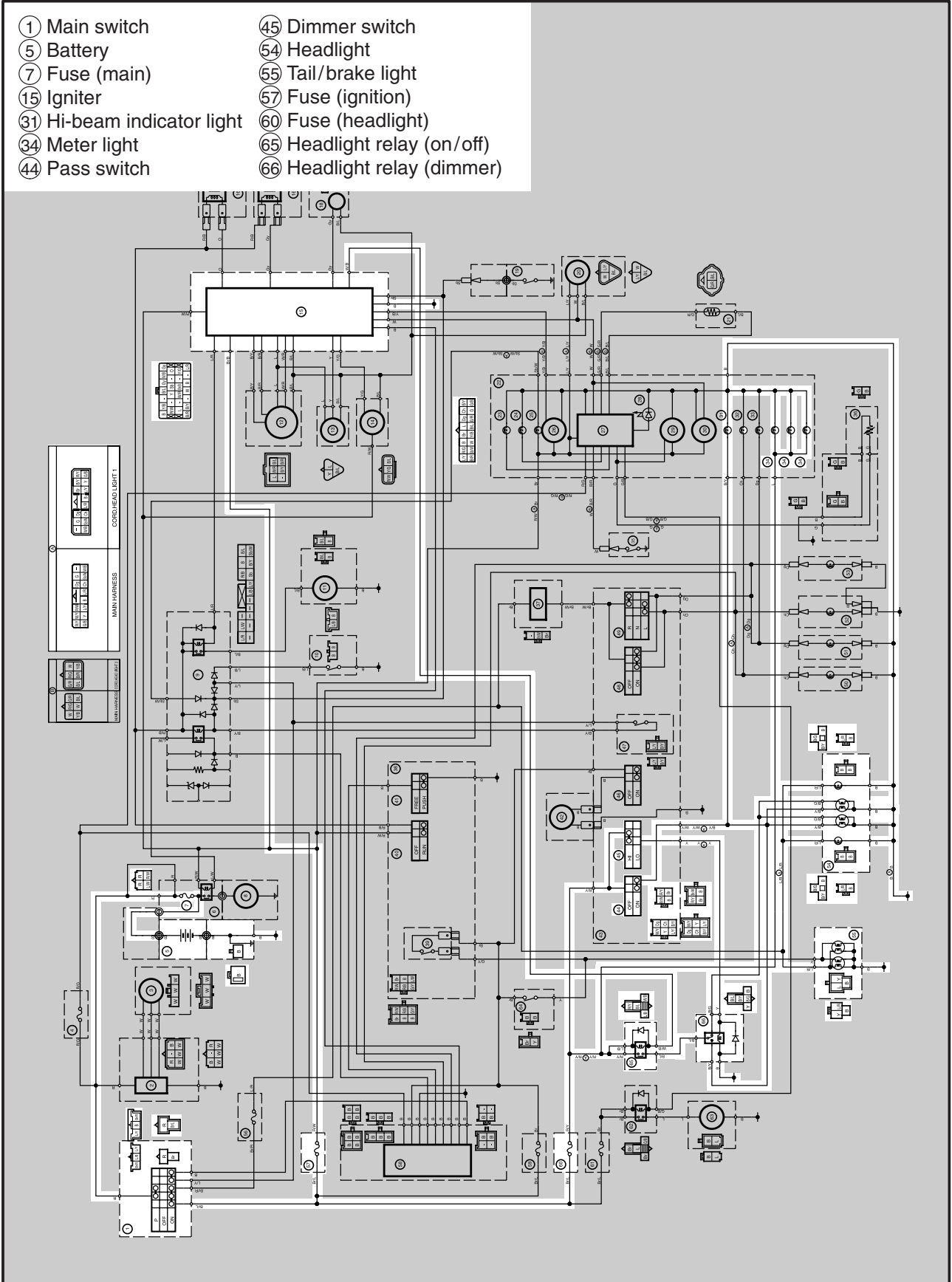

# LIGHTING SYSTEM



EAS00781

## TROUBLESHOOTING

**Any of the following fail to light: headlight, high beam indicator light, taillight, auxiliary light or meter light.**

Check:

1. Main, headlight and ignition fuses
2. Battery
3. Main switch
4. Dimmer switch
5. Pass switch
6. Headlight relay (on/off) (for EUR)
7. Headlight relay (dimmer)
8. Wiring connections (of the entire charging system)

### NOTE:

- Before troubleshooting, remove the following part(-s):
  - 1) Seat
  - 2) Fuel tank
  - 3) Side cover
- Troubleshoot with the following special tool(-s).

	<b>Pocket tester</b> <b>90890-03112</b>
--	--

EAS00738

<b>1. Main, headlight and ignition fuses</b>
• Check the main, headlight and ignition fuses for continuity. Refer to "CHECKING THE FUSES" in CHAPTER 3. (Manual No.: 5LV1-AE1)
• Are the main, headlight and ignition fuses OK?



Replace the fuse(s).

EAS00739

<b>2. Battery</b>		
• Check the condition of the battery. Refer to "CHECKING THE BATTERY" in CHAPTER 3. (Manual No.: 5LV1-AE1)		
<table border="1"> <tr> <td style="text-align: center;"></td> <td> <b>Minimum open-circuit voltage</b>  <b>12.8 V or more at 20° C</b> </td> </tr> </table>		<b>Minimum open-circuit voltage</b> <b>12.8 V or more at 20° C</b>
	<b>Minimum open-circuit voltage</b> <b>12.8 V or more at 20° C</b>	
• Is the battery OK?		



• Clean the battery terminals.  
 • Recharge or replace the battery.

EAS00749

<b>3. Main switch</b>
• Check the main switch for continuity. Refer to "CHECKING THE SWITCHES".
• Is the main switch OK?



Replace the main switch.

EAS00784

<b>4. Dimmer switch</b>
• Check the dimmer switch for continuity. Refer to "CHECKING THE SWITCHES".
• Is the dimmer switch OK?



The dimmer switch is faulty. Replace the left handlebar switch.

EAS00786

<b>5. Pass switch</b>
• Check the pass switch for continuity. Refer to "CHECKING THE SWITCHES".
• Is the pass switch OK?



The pass switch is faulty. Replace the left handlebar switch.

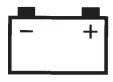

**6. Headlight relay (on/off) (for EUR)**

- Disconnect the headlight relay (on/off) from the coupler.
- Connect the pocket tester ( $\Omega \times 1$ ) and battery (12 V) to the headlight relay (on/off) coupler as shown.

**Positive battery lead** → blue/black ①  
**Negative battery lead** → black ②

**Positive tester probe** → red/yellow ③  
**Negative tester probe** → black/blue ④

• Does the headlight relay (on/off) have continuity between red/yellow and black/blue?

↓ YES      ↓ NO

Replace the headlight relay (on/off).

**7. Headlight relay (dimmer)**

- Disconnect the headlight relay (dimmer) from the coupler.
- Connect the pocket tester ( $\Omega \times 1$ ) and battery (12 V) to the headlight relay (dimmer) coupler as shown.

**Low-beam**  
**Positive tester probe** → black/blue ①  
**Negative tester probe** → black/green ②

• Does the headlight relay (dimmer) have continuity?

↓ YES      ↓ NO

Replace the headlight relay (dimmer).

**8. Wiring**

- Check entire lighting system's wiring. Refer to "CIRCUIT DIAGRAM".
- Is the lighting system's wiring properly connected and without defects?

↓ YES      ↓ NO

Check the condition of each of the lighting system's circuits. Refer to "CHECKING THE LIGHTING SYSTEM". (Manual No.: 5LV1-AE1)

Properly connect or repair the lighting system's wiring.

**Hi-beam**  
**Positive battery lead** → yellow ①  
**Negative battery lead** → black ②

**Positive tester probe** → black/blue ③  
**Negative tester probe** → black/yellow ④

• Does the headlight relay (dimmer) have continuity?

↓ YES      ↓ NO

Replace the headlight relay (dimmer).

EAS00787

**8. Wiring**

- Check entire lighting system's wiring. Refer to "CIRCUIT DIAGRAM".
- Is the lighting system's wiring properly connected and without defects?

↓ YES      ↓ NO

Check the condition of each of the lighting system's circuits. Refer to "CHECKING THE LIGHTING SYSTEM". (Manual No.: 5LV1-AE1)

Properly connect or repair the lighting system's wiring.

EAS00788

**CHECKING THE LIGHTING SYSTEM**

1. The headlight and the high beam indicator light fail to come on.

1. Headlight bulb and socket



- Check the headlight bulb and socket for continuity.
- Are the headlight bulb and socket OK?



Replace the headlight bulb, socket or both.

2. Voltage

- Connect the pocket tester (DC 20 V) to the headlight and high beam indicator light couplers as shown.

- A When the dimmer switch is set to “ ”.
- B When the dimmer switch is set to “ ”.

**Headlight**

**Positive tester probe** → black/yellow ① or black/green ②  
**Negative tester probe** → black ③

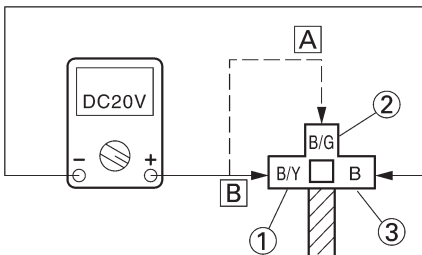

**High beam indicator light**  
**Positive tester probe** → black/yellow ④  
**Negative tester probe** → black ⑤

Headlight coupler (wire harness side)

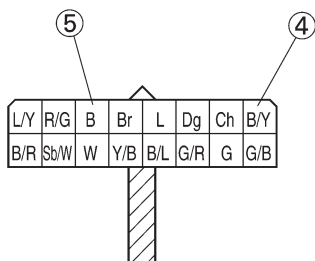

Meter light coupler (wire harness side)



- Set the main switch to “ON”.
- Start the engine.
- Set the dimmer switch to “ ” or “ ”.
- Measure the voltage (12 V) (wire harness side).

• Is the voltage within specification?



This circuit is OK.

3. Wiring

- Check the entire lighting system’s wiring. Refer to “CIRCUIT DIAGRAM”.
- Is the lighting system’s wiring properly connected and without defects?



Properly connect or repair the lighting system’s wiring.

Replace the ignitor unit.

EAS00789

2. The meter light fails to come on.

1. Meter light bulb and socket

- Check the meter light bulb and socket for continuity.
- Are the meter light bulb and socket OK?



Replace the meter light bulb, socket of both.

2. Voltage

- Connect the pocket tester (DC 20 V) to the meter light coupler (wire harness side) as shown.



**Positive tester probe → blue ①**  
**Negative tester probe → black ②**

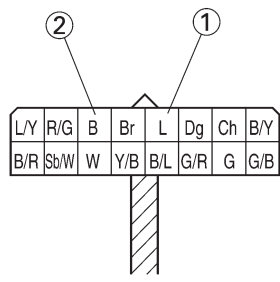

- Set the main switch to “ON”.
- Start the engine.
- Measure the voltage (12 V) of blue ① on the meter light coupler (wire harness side).

• Is the voltage within specification?

↓ YES                      ↓ NO

This circuit is OK.

**3. Wiring**

- Check the entire lighting system’s wiring. Refer to “CIRCUIT DIAGRAM”.
- Is the lighting system’s wiring properly connected and without defects?

↓ NO                      ↓ YES

Check the condition of each of the lighting system’s circuits. Refer to “CHECKING THE LIGHTING SYSTEM”. (Manual No.: 5LV1-AE1)

Properly connect or repair the lighting system’s wiring.

EAS00790  
**3. The tail/brake light fails to come on.**

**1. Tail/brake light bulb and socket**

- Check the tail/brake light bulb and socket for continuity.

• Are the tail/brake light bulb and socket OK?

↓ YES                      ↓ NO

Replace the tail/brake light bulb, socket or both.

**2. Voltage**

- Connect the pocket tester (DC 20 V) to the tail/brake light coupler (wire harness side) as shown.

**Positive tester probe → blue/red ①**  
**Negative tester probe → black ②**

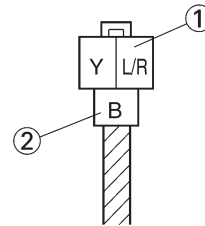

- Set the main switch to “ON”.
- Start the engine.
- Measure the voltage (12 V) of blue/red ① on the tail/brake light coupler (tail/brake light side).

• Is the voltage within specification?

↓ YES                      ↓ NO

This circuit is OK.

**3. Wiring**

- Check the entire lighting system’s wiring. Refer to “CIRCUIT DIAGRAM”.
- Is the lighting system’s wiring properly connected and without defects?

↓ NO                      ↓ YES

Check the condition of each of the lighting system’s circuits. Refer to “CHECKING THE LIGHTING SYSTEM”. (Manual No.: 5LV1-AE1)

Properly connect or repair the lighting system’s wiring.

EAS00866

**FAULTY LIGHTING OR SIGNALING SYSTEM****HEADLIGHT DOES NOT LIGHT**

- Wrong headlight bulb
- Too many electrical accessories
- Hard charging
- Incorrect connection
- Improperly grounded circuit
- Poor contacts (main switch)
- Burnt-out headlight bulb

**HEADLIGHT BULB BURNT OUT**

- Wrong headlight bulb
- Faulty battery
- Faulty rectifier/regulator
- Improperly grounded circuit
- Faulty main switch
- Headlight bulb life expired

**TAIL/BRAKE LIGHT DOES NOT LIGHT**

- Wrong tail/brake light bulb
- Too many electrical accessories
- Incorrect connection
- Burnt-out tail/brake light bulb

**TAIL/BRAKE LIGHT BULB BURNT OUT**

- Wrong tail/brake light bulb
- Faulty battery
- Incorrectly adjusted rear brake light switch
- Tail/brake light bulb life expired

**TURN SIGNAL DOES NOT LIGHT**

- Faulty turn signal switch
- Faulty turn signal relay
- Burnt-out turn signal bulb
- Incorrect connection
- Damaged or faulty wire harness
- Improperly grounded circuit
- Faulty battery
- Blown, damaged or incorrect fuse

**TURN SIGNAL BLINKS SLOWLY**

- Faulty turn signal relay
- Faulty main switch
- Faulty turn signal switch
- Incorrect turn signal bulb

**TURN SIGNAL REMAINS LIT**

- Faulty turn signal relay
- Burnt-out turn signal bulb

**TURN SIGNAL BLINKS QUICKLY**

- Incorrect turn signal bulb
- Faulty turn signal relay
- Burnt-out turn signal bulb

**HORN DOES NOT SOUND**

- Improperly adjusted horn
- Damaged or faulty horn
- Faulty main switch
- Faulty horn switch
- Faulty battery
- Blown, damaged or incorrect fuse
- Faulty wire harness





YAMAHA MOTOR CO., LTD.  
2500 SHINGAI IWATA SHIZUOKA JAPAN

# FZS1000 2003 WIRING DIAGRAM (EUR)

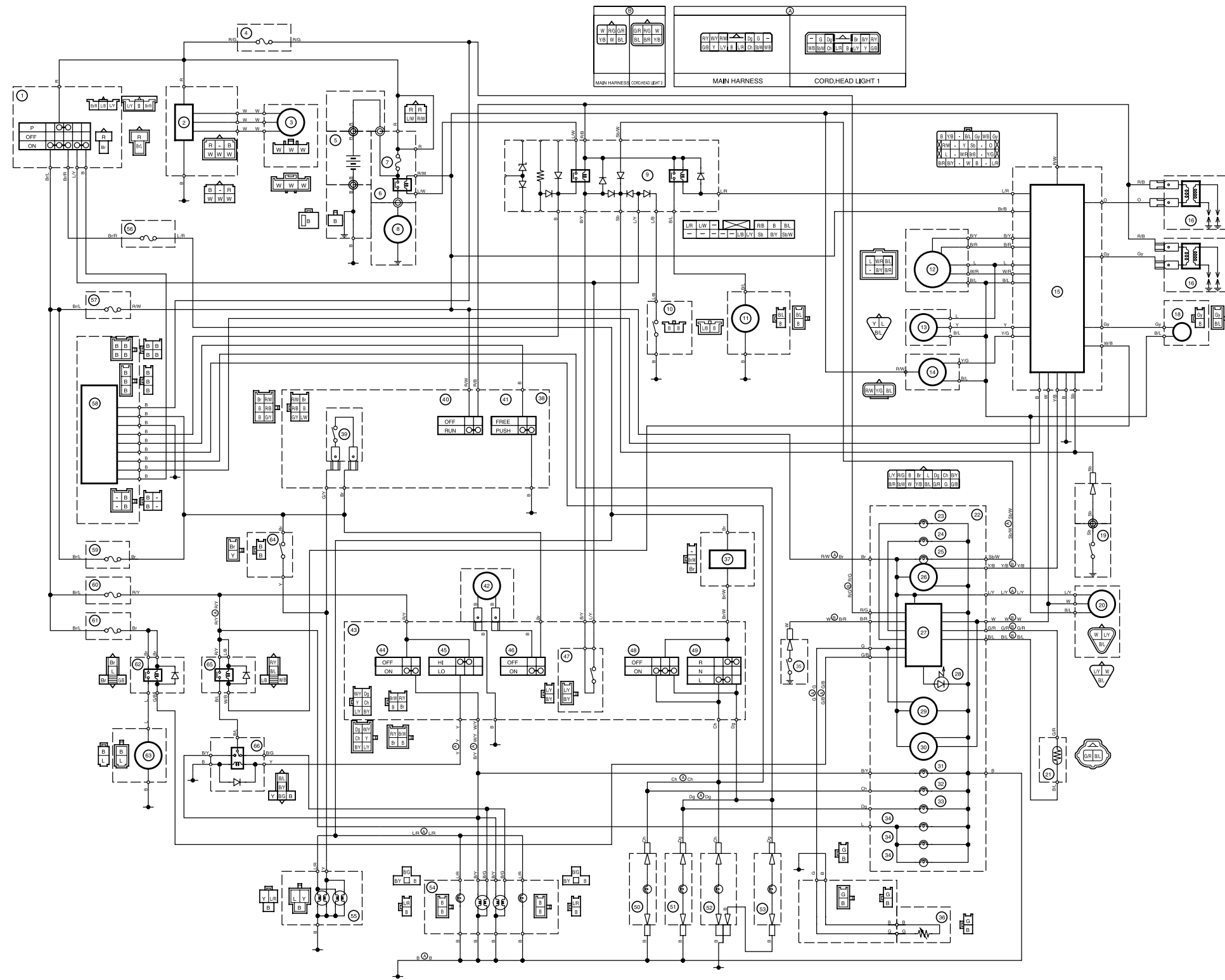

- |                                       |                                    |
|---------------------------------------|------------------------------------|
| ① Main switch                         | ③④ Meter light                     |
| ② Rectifier/regulator                 | ③⑤ Oil level gauge                 |
| ③ AC magneto                          | ③⑥ Fuel sender                     |
| ④ Fuse (back up)                      | ③⑦ Turn signal relay               |
| ⑤ Battery                             | ③⑧ Handlebar switch (right)        |
| ⑥ Starter relay                       | ③⑨ Front brake light switch        |
| ⑦ Fuse (main)                         | ④⑩ Engine stop switch              |
| ⑧ Starter motor                       | ④⑪ Start switch                    |
| ⑨ Starting circuit cutoff relay       | ④⑫ Horn                            |
| ⑩ Sidestand switch                    | ④⑬ Handlebar switch (left)         |
| ⑪ Fuel pump                           | ④⑭ Pass switch                     |
| ⑫ EXUP servo motor                    | ④⑮ Dimmer switch                   |
| ⑬ T.P.S.                              | ④⑯ Horn switch                     |
| ⑭ Emergency stop switch               | ④⑰ Clutch switch                   |
| ⑮ Igniter                             | ④⑱ Hazard switch                   |
| ⑯ Ignition coil                       | ④⑲ Turn signal switch              |
| ⑰ Spark plug                          | ④⑳ Front turn signal light (left)  |
| ⑱ Pickup coil                         | ④㉑ Front turn signal light (right) |
| ⑲ Neutral switch                      | ④㉒ Rear turn signal light (left)   |
| ⑳ Speed sensor                        | ④㉓ Rear turn signal light (right)  |
| ㉑ Thermo unit                         | ④㉔ Headlight                       |
| ㉒ Meter assembly                      | ④㉕ Tail/brake light                |
| ㉓ Fuel level warning light            | ④㉖ Fuse (turn signal)              |
| ㉔ Oil level warning light             | ④㉗ Fuse (ignition)                 |
| ㉕ Neutral indicator light             | ④㉘ Alarm                           |
| ㉖ Tacho meter                         | ④㉙ Fuse (alarm)                    |
| ㉗ Combination meter                   | ④㉚ Fuse (headlight)                |
| ㉘ Water temp warning light            | ④㉛ Fuse (fan)                      |
| ㉙ Fuel gauge                          | ④㉜ Fan motor relay                 |
| ㉚ Speedometer                         | ④㉝ Fan motor                       |
| ㉛ Hi-beam indicator light             | ④㉞ Rear brake light switch         |
| ㉜ Turn signal indicator light (left)  | ④㉟ Headlight relay (on/off)        |
| ㉝ Turn signal indicator light (right) | ④㊱ Head light relay (dimmer)       |

- |                          |                         |
|--------------------------|-------------------------|
| B . . . . . Black        | Br/R . . . Brown/Red    |
| Br . . . . . Brown       | Br/W . . . Brown/White  |
| Ch . . . . . Chocolate   | G/B . . . Green/Black   |
| Dg . . . . . Dark green  | G/R . . . Green/Red     |
| G . . . . . Green        | G/W . . . Green/White   |
| Gy . . . . . Gray        | G/Y . . . Green/Yellow  |
| L . . . . . Blue         | L/B . . . Blue/Black    |
| Lg . . . . . Light green | L/R . . . Blue/Red      |
| O . . . . . Orange       | L/W . . . Blue/White    |
| P . . . . . Pink         | L/Y . . . Blue/Yellow   |
| R . . . . . Red          | O/R . . . Orange/Red    |
| Sb . . . . . Sky blue    | R/B . . . Red/Black     |
| W . . . . . White        | R/G . . . Red/Green     |
| Y . . . . . Yellow       | R/W . . . Red/White     |
| B/G . . . Black/Green    | R/Y . . . Red/Yellow    |
| B/L . . . Black/Blue     | Sb/W . . Sky blue/White |
| B/R . . . Black/Red      | W/R . . . White/Red     |
| B/W . . . Black/White    | W/Y . . . White/Yellow  |
| B/Y . . . Black/Yellow   | Y/B . . . Yellow/Black  |
| Br/B . . . Brown/Black   | Y/G . . . Yellow/Green  |
| Br/L . . . Brown/Blue    |                         |

# FZS1000R 2003 WIRING DIAGRAM (OCE)

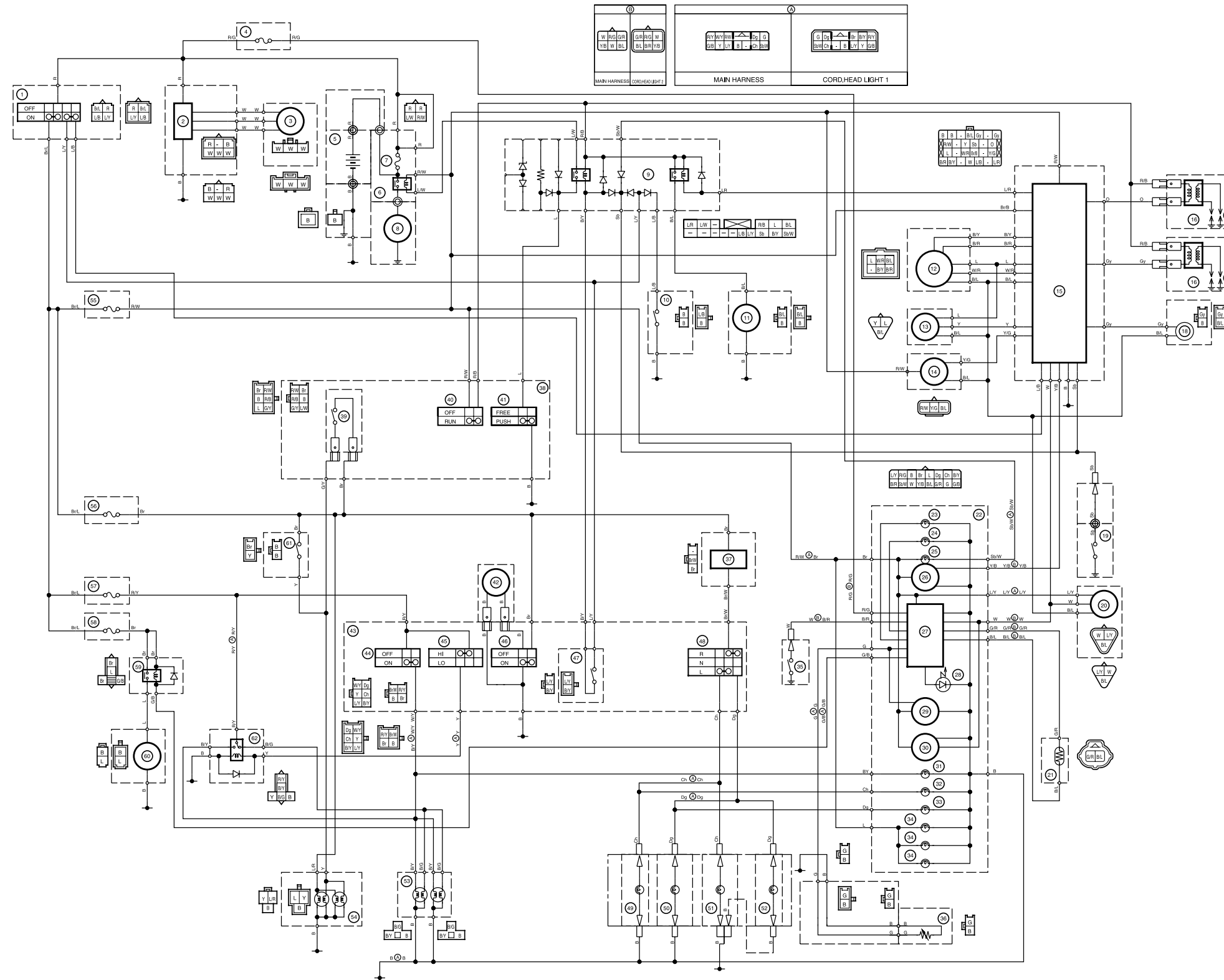

- |                                 |  |
|---------------------------------|--|
| ① Main switch                   | ③② Turn signal indicator light (left)  |
| ② Rectifier/regulator           | ③③ Turn signal indicator light (right) |
| ③ AC magneto                    | ③④ Meter light                         |
| ④ Fuse (back up)                | ③⑤ Oil level gauge                     |
| ⑤ Battery                       | ③⑥ Fuel sender                         |
| ⑥ Starter relay                 | ③⑦ Turn signal relay                   |
| ⑦ Fuse (main)                   | ③⑧ Handlebar switch (right)            |
| ⑧ Starter motor                 | ③⑨ Front brake light switch            |
| ⑨ Starting circuit cutoff relay | ④⑩ Engine stop switch                  |
| ⑩ Sidestand switch              | ④⑪ Start switch                        |
| ⑪ Fuel pump                     | ④⑫ Horn                                |
| ⑫ EXUP servo motor              | ④⑬ Handlebar switch (left)             |
| ⑬ T.P.S.                        | ④⑭ Pass switch                         |
| ⑭ Emergency stop switch         | ④⑮ Dimmer switch                       |
| ⑮ Igniter                       | ④⑯ Horn switch                         |
| ⑯ Ignition coil                 | ④⑰ Clutch switch                       |
| ⑰ Spark plug                    | ④⑱ Turn signal switch                  |
| ⑱ Pickup coil                   | ④⑲ Front turn signal light (left)      |
| ⑲ Neutral switch                | ④⑳ Front turn signal light (right)     |
| ⑳ Speed sensor                  | ④㉑ Rear turn signal light (left)       |
| ㉑ Thermo unit                   | ④㉒ Rear turn signal light (right)      |
| ㉒ Meter assembly                | ④㉓ Headlight                           |
| ㉓ Fuel level warning light      | ④㉔ Tail/brake light                    |
| ㉔ Oil level warning light       | ④㉕ Fuse (ignition)                     |
| ㉕ Neutral indicator light       | ④㉖ Fuse (turn signal)                  |
| ㉖ Tacho meter                   | ④㉗ Fuse (headlight)                    |
| ㉗ Combination meter             | ④㉘ Fuse (fan)                          |
| ㉘ Water temp warning light      | ④㉙ Fan motor relay                     |
| ㉙ Fuel gauge                    | ④㉚ Fan motor                           |
| ㉚ Speedometer                   | ④㉛ Rear brake light switch             |
| ㉛ Hi-beam indicator light       | ④㉜ Head light relay (dimmer)           |

- |                       |                         |
|-----------------------|-------------------------|
| B ..... Black         | Br/R .... Brown/Red     |
| Br ..... Brown        | Br/W .... Brown/White   |
| Ch ..... Chocolate    | G/B .... Green/Black    |
| Dg ..... Dark green   | G/R .... Green/Red      |
| G ..... Green         | G/W .... Green/White    |
| Gy ..... Gray         | G/Y .... Green/Yellow   |
| L ..... Blue          | L/B .... Blue/Black     |
| Lg ..... Light green  | L/R .... Blue/Red       |
| O ..... Orange        | L/W .... Blue/White     |
| P ..... Pink          | L/Y .... Blue/Yellow    |
| R ..... Red           | O/R .... Orange/Red     |
| Sb ..... Sky blue     | R/B .... Red/Black      |
| W ..... White         | R/G .... Red/Green      |
| Y ..... Yellow        | R/W .... Red/White      |
| B/G .... Black/Green  | R/Y .... Red/Yellow     |
| B/L .... Black/Blue   | Sb/W ... Sky blue/White |
| B/R .... Black/Red    | W/R .... White/Red      |
| B/W .... Black/White  | W/Y .... White/Yellow   |
| B/Y .... Black/Yellow | Y/B .... Yellow/Black   |
| Br/B .... Brown/Black | Y/G .... Yellow/Green   |
| Br/L .... Brown/Blue  |                         |